

Frequency Inverter

Convertidor de Frecuencia

Inversor de Frequência

CFW-11

User's Guide
Manual del Usuario
Manual do Usuário

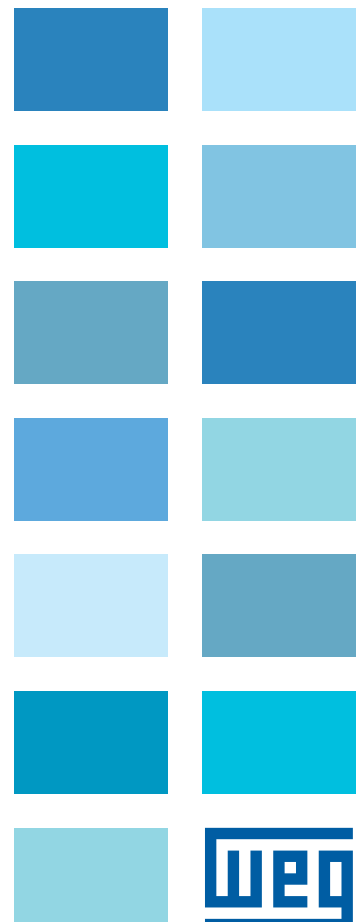

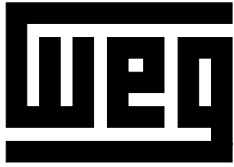

CFW-11 VECTRUE INVERTER

FREQUENCY INVERTER MANUAL

Series: CFW-11

Language: English

Document: 10000280997 / 00

Models: 142...211 A / 220...230 V

105...211 A / 380...480 V

Summary of Revisions

Revision	Description	Chapter
1	First Edition	-

CHAPTER 1
Safety Instructions

1.1 Safety Warnings in the Manual.....	1-1
1.2 Safety Warnings in the Product.....	1-1
1.3 Preliminary Recommendations	1-2

CHAPTER 2
General Instructions

2.1 About the Manual	2-1
2.2 Terms and Definitions.....	2-1
2.3 About the CFW-11	2-4
2.4 Identification Labels for the CFW-11	2-7
2.5 Receiving and Storage	2-10

CHAPTER 3
Installation and Connection

3.1 Mechanical Installation	3-1
3.1.1 Installation Environment.....	3-1
3.1.2 Mounting Considerations.....	3-1
3.1.3 Cabinet Mounting	3-4
3.1.4 Installation of the Inverter Hoisting Eyes.....	3-5
3.1.5 Installation of the Inverter with Nema 1 Kit (Optional, CFW11XXXXTXON1) on a Wall.....	3-6
3.1.6 Access to the Control and Power Terminal Strips.....	3-6
3.1.7 Removal of the Cable Passage Plate	3-8
3.1.8 HMI Installation at the Cabinet Door or Command Panel (Remote HMI)	3-8
3.2 Electrical Installation	3-9
3.2.1 Identification of the Power and Grounding Terminals	3-9
3.2.2 Power / Grounding Wiring and Fuses.....	3-10
3.2.3 Power Connections.....	3-14
3.2.3.1 Input Connections	3-14
3.2.3.1.1 IT Networks	3-15
3.2.3.1.2 Command Fuses	3-16
3.2.3.2 Dynamic Braking.....	3-16
3.2.3.2.1 Sizing the Braking Resistor.....	3-17
3.2.3.2.2 Installation of the Braking Resistor.....	3-18
3.2.3.3 Output Connections	3-19
3.2.4 Grounding Connections	3-21
3.2.5 Control Connections	3-22
3.2.6 Typical Control Connections.....	3-26
3.3 Installation According to the European Directive of Electromagnetic Compatibility	3-29
3.3.1 Conformal Installation	3-29
3.3.2 Standard Definitions	3-30
3.3.3 Emission and Immunity Levels.....	3-31

**CHAPTER 4
KEYPAD AND DISPLAY**

4.1 Integral Keypad - HMI-CFW114-1
4.2 Parameters Organization4-4

**CHAPTER 5
First Time Power-Up and Start-Up**

5.1 Prepare for Start-Up5-1
5.2 Start-Up5-2
 5.2.1 Password Setting in P00005-2
 5.2.2 Oriented Start-up5-3
 5.2.3 Setting Basic Application Parameters5-5
5.3 Setting Date and Time5-8
5.4 Blocking Parameters Modification5-8
5.5 How to Connect a PC5-9
5.6 FLASH Memory Module5-9

**CHAPTER 6
Troubleshooting and Maintenance**

6.1 Operation of the Faults and Alarms6-1
6.2 Faults, Alarms, and Possible Causes6-2
6.3 Solutions for the Most Frequent Problems6-5
6.4 Information for Contacting Technical Support6-6
6.5 Preventive Maintenance6-6
 6.5.1 Cleaning Instructions6-7

**CHAPTER 7
Option Kits and Accessories**

7.1 Option Kits7-1
 7.1.1 Braking IGBT7-1
 7.1.2 Nema1 Protection Degree7-1
 7.1.3 Safety Stop According to EN 954-1 Category 3 (Pending Certification)7-1
 7.1.4 24 Vdc External Control Power Supply7-2
7.2 Accessories7-3

**CHAPTER 8
Technical Specifications**

8.1 Power Data8-1
8.2 Electrical / General Specifications8-6
 8.2.1 Codes and Standards8-7
8.3 Mechanical Data8-8
8.4 NEMA1 Kit8-9

SAFETY INSTRUCTIONS

This manual provides information for the proper installation and operation of the CFW-11 frequency inverter.

Only trained and qualified personnel should attempt to install, start-up, and troubleshoot this type of equipment.



1.1 SAFETY WARNINGS IN THE MANUAL

The following safety warnings are used in this manual:



DANGER!

Failure to follow the recommended procedures listed in this warning may result in death, serious injury, and equipment damage.



ATTENTION!

Failure to follow the recommended procedures listed in this warning may result in equipment damage.



NOTE!

This warning provides important information for the proper understanding and operation of the equipment.

1.2 SAFETY WARNINGS IN THE PRODUCT

The following symbols are attached to the product and require special attention:



Indicates a high voltage warning.



Electrostatic discharge sensitive components.
Do not touch them.



Indicates that a ground (PE) must be connected securely.



Indicates that the cable shield must be grounded.



Indicates a hot surface warning.

1.3 PRELIMINARY RECOMMENDATIONS



DANGER!

Only trained personnel, with proper qualifications, and familiar with the CFW-11 and associated machinery shall plan and implement the installation, starting, operation, and maintenance of this equipment.

The personnel shall follow all the safety instructions described in this manual and/or defined by the local regulations.

Failure to comply with the safety instructions may result in death, serious injury, and equipment damage.



NOTE!

For the purpose of this manual, qualified personnel are those trained and able to:

1. Install, ground, power-up, and operate the CFW-11 according to this manual and to the current legal safety procedures;
2. Use the protection equipment according to the established regulations;
3. Provide first aid.



DANGER!

Always disconnect the main power supply before touching any electrical device associated with the inverter.

Several components may remain charged with high voltage and/or in movement (fans), even after the AC power supply has been disconnected or turned off.

Wait at least 10 minutes to guarantee the fully discharge of capacitors.

Always connect the equipment frame to the ground protection (PE).



ATTENTION!

The electronic boards contain components sensitive to electrostatic discharges. Do not touch the components and terminals directly. If needed, touch first the grounded metal frame or wear an adequate ground strap.

**Do not perform a withstand voltage test on any part of the inverter!
If needed, please, consult WEG.**



NOTE!

Frequency inverters may cause interference in other electronic devices. Follow the recommendations listed in Chapter 3 – Installation and Connection, to minimize these effects.



NOTE!

Fully read this manual before installing or operating the inverter.



ATTENTION!

Operation of this equipment requires detailed installation and operation instructions provided in the User's Manual, Software Manual and Manual/Guides for Kits and Accessories. Only User's Manual is provided on a printed version. The other manuals are provided on the CD supplied with the product. This CD should be retained with this equipment at all times. A hard copy of this information may be ordered through your local WEG representative.

GENERAL INSTRUCTIONS

2.1 ABOUT THE MANUAL

This manual exposes how to install, to start-up in V/f (scalar) mode, the main characteristics and shows how to troubleshoot the most common problems of the CFW-11 inverter series frame size E models.

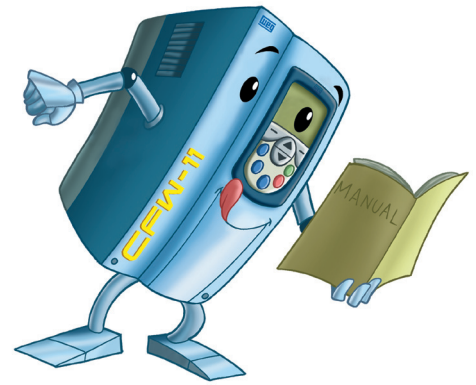

It is also possible to operate the CFW-11 in the following control modes: V V W, Sensorless Vector and Vector with Encoder. For further details on the inverter operation with other control modes, refer to the Software Manual.

For information on other functions, accessories, and communication, please refer to the following manuals:

- ☑ Software Manual, with a detailed description of the parameters and advanced functions of the CFW-11.
- ☑ Incremental Encoder Interface Module Manual.
- ☑ I/O Expansion Module Manual.
- ☑ RS-232/RS-485 Serial Communication Manual.
- ☑ CANopen Slave Communication Manual.
- ☑ Anybus-CC Communication Manual.

These manuals are included on the CD supplied with the inverter or can be downloaded from the WEG website at - www.weg.net.

2.2 TERMS AND DEFINITIONS

Normal Duty Cycle (ND): Inverter duty cycle that defines the maximum continuous operation current (I_{RAT-ND}) and the overload current (110 % for 1 minute). The ND cycle is selected by setting P0298 (Application) = 0 (Normal Duty (ND)). This duty cycle shall be used for the operation of motors that are not subjected to high torque loads (with respect to the motor rated torque) during its operation, starting, acceleration, or deceleration.

I_{RAT-ND} : Inverter rated current for use with the normal duty (ND) cycle.
Overload: $1.1 \times I_{RAT-ND} / 1$ minute.

Heavy Duty Cycle (HD): Inverter duty cycle that defines the maximum continuous operation current (I_{RAT-HD}) and the overload current (150 % for 1 minute). The HD cycle is selected by setting P0298 (Application) = 1 (Heavy Duty (HD)). This duty cycle shall be used for the operation of motors that are subjected to high torque (with respect to the motor rated torque) during its operation, starting, acceleration, or deceleration.

I_{RAT-HD} : Inverter rated current for use with the heavy duty (HD) cycle.
Overload: $1.5 \times I_{RAT-HD} / 1$ minute.

Rectifier: Input circuit of inverters that transforms the AC input voltage in DC voltage. It is composed of power diodes.

Pre-charge Circuit: Charges the DC bus capacitors with limited current, which avoids higher peak currents at the inverter power-up.

DC Bus: Inverter intermediate circuit; DC voltage obtained from the rectification of the AC input voltage or from an external power supply; feeds the output inverter bridge with IGBTs.

Power modules U, V, and W: Set of two IGBTs of the inverter output phases U, V, and W.

IGBT: Insulated Gate Bipolar Transistor; basic component of the output inverter bridge. The IGBT works as an electronic switch in the saturated (closed switch) and cut-off (open switch) modes.

Braking IGBT: Works as a switch to activate the braking resistors. It is controlled by the DC bus voltage level.

PTC: Resistor which resistance value in ohms increases proportionally to the temperature increase; used as a temperature sensor in electrical motors.

NTC: Resistor which resistance value in ohms decreases proportionally to the temperature increase; used as a temperature sensor in power modules.

HMI - Human Machine Interface: it is a device that allows the motor control, and the visualization and modification of the inverter parameters. The CFW-11 HMI presents keys for the motor command, navigation keys and a graphic LCD display.

FLASH memory: Non-volatile memory that can be electronically written and erased.

RAM memory: Random Access Memory (volatile).

USB: Universal Serial Bus; is a serial bus standard that allows devices to be connected using the "Plug and Play" concept.



PE: Protective Earth.

RFI Filter: Radio-Frequency Interference Filter for interference reduction in the Radio-Frequency range.

PWM: Pulse Width Modulation; pulsed voltage that feeds the motor.

Switching frequency: Frequency of the IGBTs switching in the inverter bridge, normally expressed in kHz.

General enable: When activated, this function accelerates the motor via acceleration ramp set in the inverter. When deactivated, this function immediately blocks the PWM pulses. The general enable function may be controlled through a digital input set to this function or via serial communication.

Start/Stop: When enabled in the inverter (start), this function accelerates the motor via acceleration ramp up to the speed reference. When disabled (stop), this function decelerates the motor via deceleration ramp up to the complete motor stop; at this point, the PWM pulses are blocked. The start/stop function may be controlled through a digital input set for this function or via serial communication. The operator keys  (Start) and  (Stop) of the keypad work in a similar way.

Heatsink: Metal device designed to dissipate the heat generated by the power semiconductors.

PLC: Programmable Logic Controller.

°C: Celsius degree.

°F: Fahrenheit degree.

AC: Alternated Current.

Amp, A: Ampères.

CFM: Cubic Feet per Minute; unit of flow.

cm: Centimeter.

DC: Direct Current.

ft: Foot.

hp: Horse Power = 746 Watts; unit of power, used to indicate the mechanical power of electrical motors.

Hz: Hertz.

in: Inch.

kg: Kilogram = 1000 grams.

kHz: Kilohertz = 1000 Hertz.

l/s: Liters per second.

lb: Pound.

m: Meter.

mA: Milliampère = 0.001 Ampère.

min: Minute.

mm: Millimeter.

ms: Millisecond = 0.001 seconds.

Nm: Newton meter; unit of torque.

rms: "Root mean square"; effective value.

rpm: Revolutions per minute; unit of speed.

s: Second.

V: Volts.

Ω: Ohms.

2.3 ABOUT THE CFW-11

The CFW-11 frequency inverter is a high performance product designed for speed and torque control of three-phase induction motors. The main characteristic of this product is the "Vectrue" technology, which has the following advantages:

- ☑ Scalar control (V/f), VVW, or vector control programmable in the same product;
- ☑ The vector control may be programmed as "sensorless" (which means standard motors without using encoders) or as "vector control" with the use of an encoder;
- ☑ The "sensorless" control allows high torque and fast response, even in very low speeds or at the starting;
- ☑ The "vector with encoder" control allows high speed precision for the whole speed range (even with a standstill motor);
- ☑ "Optimal Braking" function for the vector control, allowing the controlled braking of the motor and avoiding the use of the braking resistor in some applications;
- ☑ "Self-Tuning" feature for vector control. It allows the automatic adjustment of the regulators and control parameters from the identification (also automatic) of the motor parameters and load.

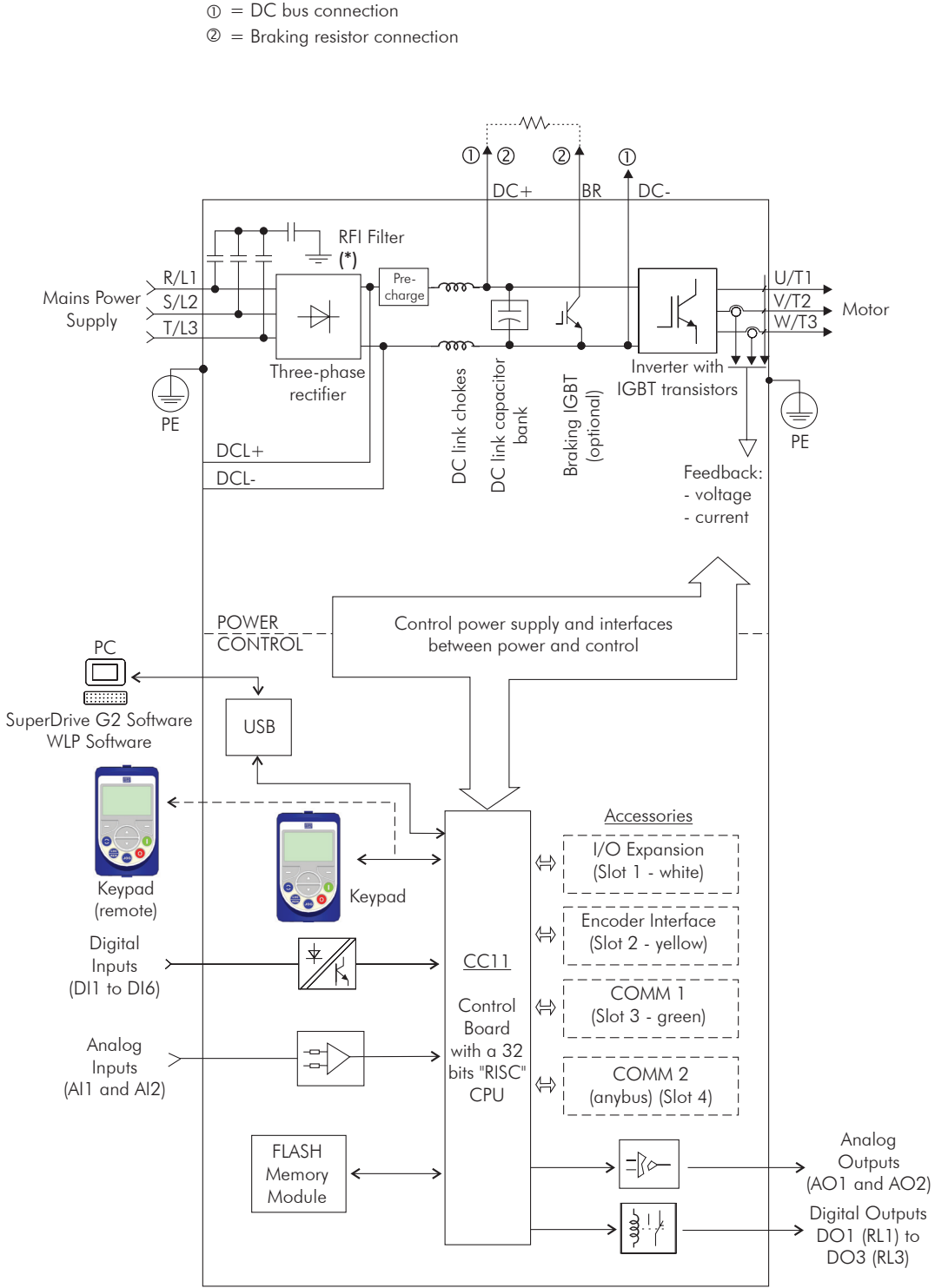

(*) The RFI filter capacitor against the ground must be disconnected with IT and grounded delta networks. Refer to the section 3.2.3.1.1 for more details.

Figure 2.1 - Block diagram for the CFW-11

2

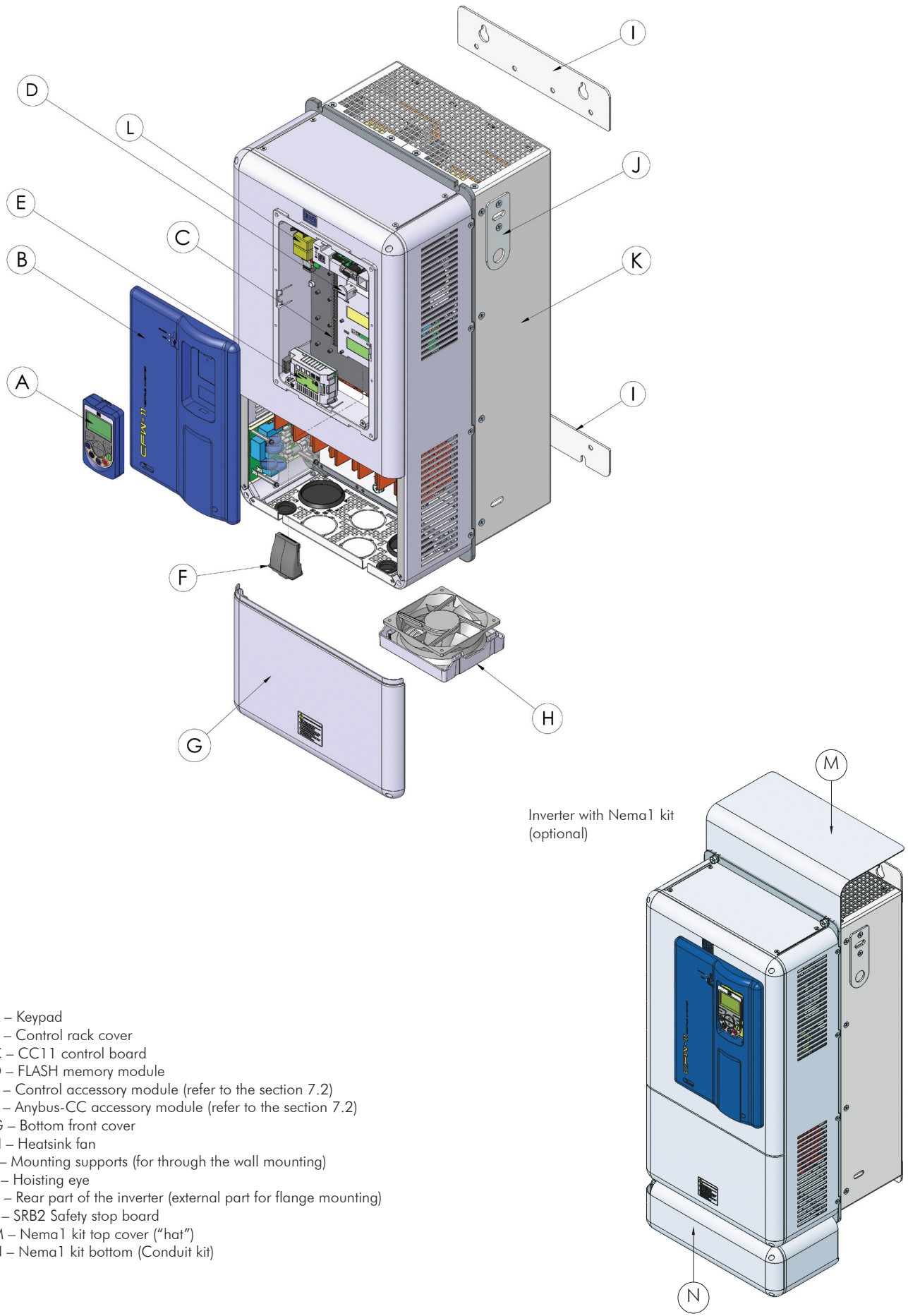

Inverter with Nema1 kit (optional)

- A – Keypad
- B – Control rack cover
- C – CC11 control board
- D – FLASH memory module
- E – Control accessory module (refer to the section 7.2)
- F – Anybus-CC accessory module (refer to the section 7.2)
- G – Bottom front cover
- H – Heatsink fan
- I – Mounting supports (for through the wall mounting)
- J – Hoisting eye
- K – Rear part of the inverter (external part for flange mounting)
- L – SRB2 Safety stop board
- M – Nema1 kit top cover ("hat")
- N – Nema1 kit bottom (Conduit kit)

Figure 2.2 - Main components of the CFW-11

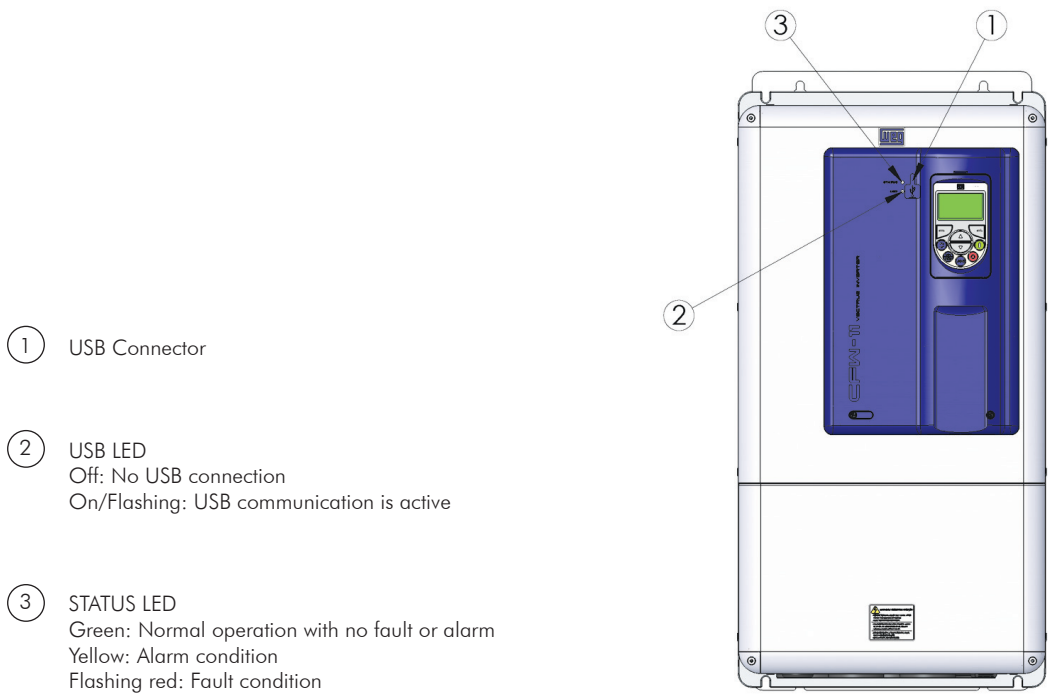

- ① USB Connector
- ② USB LED
Off: No USB connection
On/Flashing: USB communication is active
- ③ STATUS LED
Green: Normal operation with no fault or alarm
Yellow: Alarm condition
Flashing red: Fault condition

Figure 2.3 - LEDs and USB connector

2.4 IDENTIFICATION LABELS FOR THE CFW-11

There are two nameplates on the CFW-11: one complete nameplate is affixed to the side of the inverter and a simplified one is located under the keypad. The nameplate under the keypad allows the identification of the most important characteristics of the inverter even if they are mounted side-by-side.

WEG		
CFW-11 model	MOD.: CFW110211T4SZ	99/99/9999
WEG part number	MAT.: 12345678	SERIAL#: 1234567890
	OP.: 12345678	MAX. TA: 45°C (113°F)
Inverter net weight	PESO/WEIGHT: 6,3kg (13,9lb)	V1.23
Input rated data (voltage, number of phases, rated currents for operation with ND and HD overload cycles, and frequency)	LINE LINEA REDE	OUTPUT SALIDA SAIDA
	VAC 200-240V 3~	0-LINE 3~
Current specifications for operation with normal overload cycle (ND)	A (ND) 60s/3s	211A 232,1A / 316,5A
Current specifications for operation with heavy overload cycle (HD)	A (HD) 60s/3s	180A 270A / 360A
	Hz 50-60Hz	0-300Hz
Available certifications	FABRICADO NO BRASIL HECHO EN BRASIL MADE IN BRAZIL UL US LISTED IND. CONT. EQ. 2899 CE IEC RAM 7 891331 001094	

Manufacturing date (day/month/year)
Serial number
Maximum surrounding air temperature
Software Version
Output rated data (voltage, number of phases, rated currents for operation with ND and HD overload cycles, overload currents for 1 min and 3 s, and frequency range)

(a) Nameplate affixed to the side of the inverter

CFW-11 model	CFW110211T4SZ	
WEG part number	12345678	99/99/9999
	SERIAL#: 1234567890	

Manufacturing date (day/month/year)
Serial number

(b) Nameplate located under the keypad

Figure 2.4 (a) and (b) - Nameplates

2

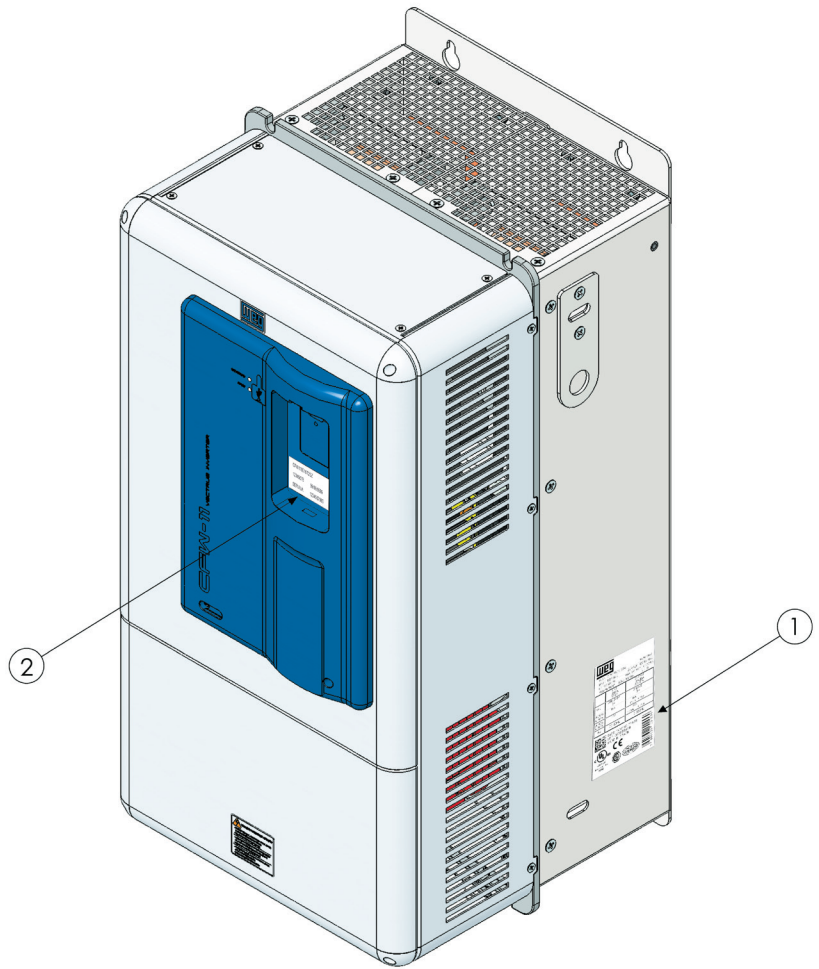

- ① Nameplate affixed to the side of the heatsink
- ② Nameplate under the keypad

Figure 2.5 - Location of the nameplates

HOW TO CODIFY THE CFW-11 MODEL (SMART CODE)

INVERTER MODEL		AVAILABLE OPTION KITS (CAN BE INSTALLED IN THE PRODUCT FROM THE FACTORY)														
Refer to the CFW-11 series frame size E model list in the chapter 8, where the technical specifications of the inverters are also presented		Refer to chapter 8 to check option kit availability for each inverter model														
Example	Field description	BR	CFW11	0211	T	4	S	--	--	--	--	--	Z			
		Market identification (defines the manual language and the factory settings)	WEG CFW-11 frequency inverter series	Rated output current for use with the Normal Duty (ND) cycle	Number of power phases	Power supply voltage	Option kit	Enclosure type	Keypad	Braking	RFI filter	Safety stop	24 Vdc external power supply for control	Special hardware	Special software	Character that identifies the code end
Available options		2 characters	220...230 V models: 0142 = 115 A (HD) / 142 A (ND) 0180 = 142 A (HD) / 180 A (ND) 0211 = 180 A (HD) / 211 A (ND) 380...480 V models: 0105 = 88 A (HD) / 105 A (ND) 0142 = 115 A (HD) / 142 A (ND) 0180 = 142 A (HD) / 180 A (ND) 0211 = 180 A (HD) / 211 A (ND)	T=three-phase power supply	2=220...230 V 4=380...480 V	S=standard product O=product with option kit	Blank=standard (IP20) N1=Nema1	Blank=standard keypad IC=no keypad (blind cover)	Blank=standard (no braking IGBT) DB=with braking IGBT	Blank=standard (with internal RFI filter)	Blank=standard (safety stop function is not available) Y=with safety stop function according to EN-954-1 category 3	Blank=standard (not available) W=24 Vdc external power supply for control	Blank=standard H1=special hardware #1 S1=special software #1			

2.5 RECEIVING AND STORAGE

The CFW-11 frame size E models are supplied packed in wooden boxes.

There is an identification label affixed to the outside of this package, the same one that is affixed to the side of the CFW-11 inverter.

Follow the instructions below to remove the CFW-11 from the package:

- 1- Put the shipping container over a flat and stable area with the assistance of another two people;
- 2- Open the wood crate;
- 3- Remove all the packing material (the cardboard or styrofoam protection) before removing the inverter.

Check the following items once the inverter is delivered:

- Verify that the CFW-11 nameplate corresponds to the model number on your purchase order;
- Inspect the CFW-11 for external damage during transportation.

Report any damage immediately to the carrier that delivered your CFW-11 inverter.

If CFW-11 is to be stored for some time before use, be sure that it is stored in a clean and dry location that conforms to the storage temperature specification (between -25 °C and 60 °C (-13 °F and 140 °F)). Cover the inverter to prevent dust accumulation inside it.



ATTENTION!

Capacitor reforming is required if drives are stored for long periods of time without power. Refer to the procedures in item 6.5 - table 6.3.

INSTALLATION AND CONNECTION

This chapter provides information on installing and wiring the CFW-11. The instructions and guidelines listed in this manual shall be followed to guarantee personnel and equipment safety, as well as the proper operation of the inverter.

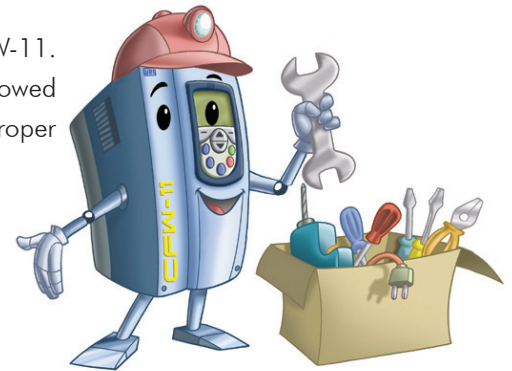

3.1 MECHANICAL INSTALLATION

3.1.1 Installation Environment

Avoid installing the inverter in an area with:

- ☑ Direct exposure to sunlight, rain, high humidity, or sea-air;
- ☑ Inflammable or corrosive gases or liquids;
- ☑ Excessive vibration;
- ☑ Dust, metallic particles, and oil mist.

Environment conditions for the operation of the inverter:

- ☑ Temperature: -10 °C to 45 °C (14 °F to 113 °F) - standard conditions (surrounding the inverter).
- ☑ From 45 °C to 55 °C (113 °F to 131 °F) - current derating of 2 % each °C (or 1.11 % each °F) above 45 °C (113 °F).
- ☑ Humidity: from 5 % to 90 % non-condensing.
- ☑ Altitude: up to 1000 m (3,300 ft) - standard conditions (no derating required).
- ☑ From 1000 m to 4000 m (3,300 ft to 13,200 ft) - current derating of 1 % each 100 m (or 0.3 % each 100 ft) above 1000 m (3,300 ft) altitude.
- ☑ Pollution degree: 2 (according to EN50178 and UL508C) with non-conductive pollution. Condensation shall not originate conduction through the accumulated residues.

3.1.2 Mounting Considerations

Consult the inverter weight at the table 8.1.

Mount the inverter in the upright position on a flat and vertical surface.

External dimensions and fixing holes position according to the figure 3.1. Refer to the section 8.3 for more details.

First put the screws on the surface where the inverter will be installed, install the inverter and then tighten the screws.

Minimum mounting clearances requirements for proper cooling air circulation are specified in figure 3.2.

Do not install heat sensitive components right above the inverter.



ATTENTION!

When arranging two or more inverters vertically, respect the minimum clearance A + B (figure 3.2) and provide an air deflecting plate so that the heat rising up from the bottom inverter does not affect the top inverter.



ATTENTION!

Provide conduit for physical separation of the signal, control, and power conductors (refer to item 3.2 - Electrical Installation).

3

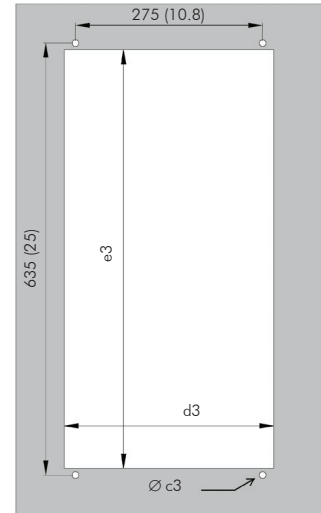
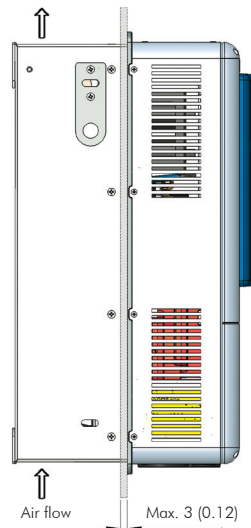
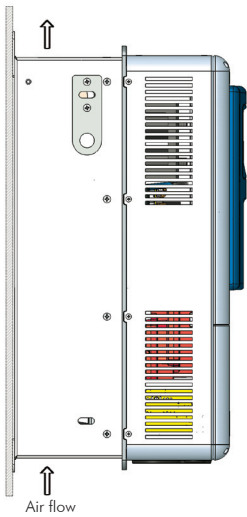
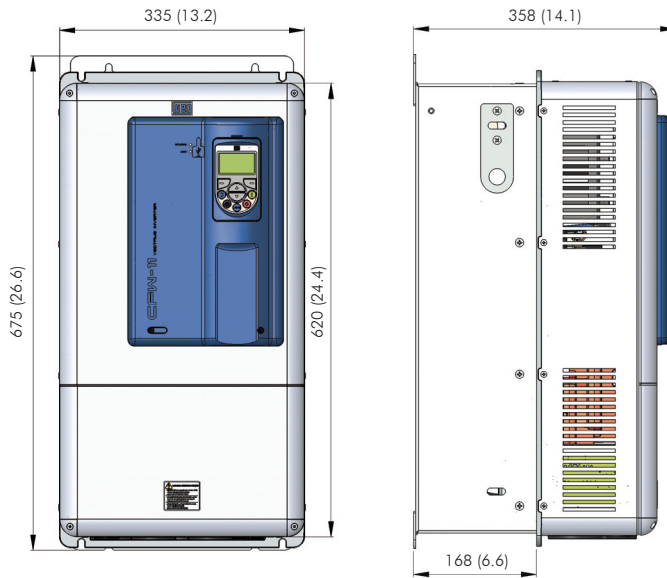

(a) Surface Mounting

(b) Flange Mounting

Model	c2	c3	d3	e3	Torque (*)
	M	M	mm (in)	mm (in)	N.m (lbf.in)
Frame E	M8	M8	315 (12.40)	615 (24.21)	20.0 (177.0)

Tolerances for dimensions d3 and e3: +1.0 mm (+0.039 in)
 Tolerances for remaining dimensions: ±1.0 mm (±0.039 in)
 (*) Recommended torque for the inverter mounting (valid for c2 and c3)

Figure 3.1 (a) and (b) - Mechanical installation details - mm (in)

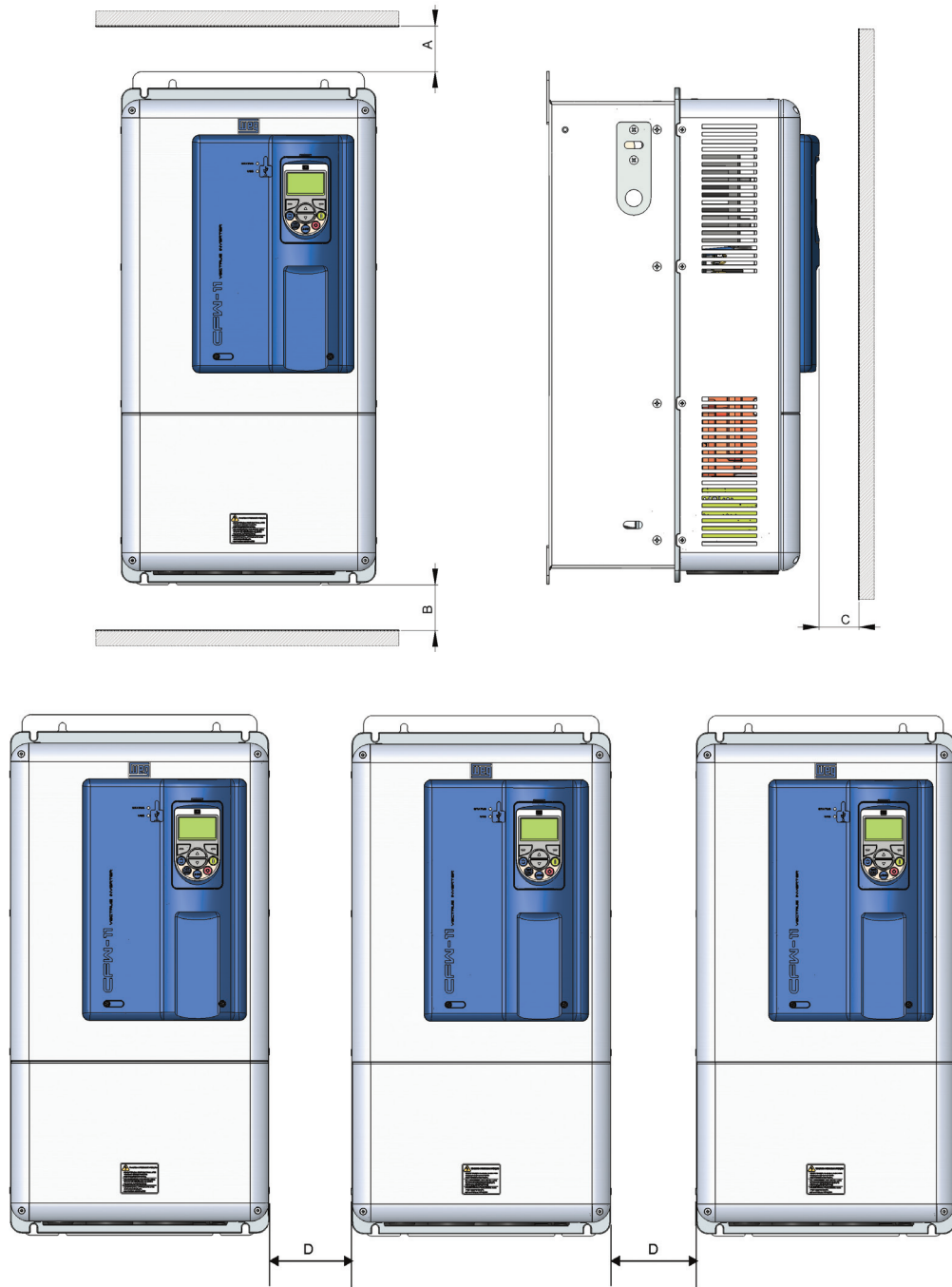

Model	A	B	C	D
	mm (in)	mm (in)		mm (in)
CFW11 0142 T 2	100 (3.94)	130 (5.12)	20 (0.78)	40 (1.57)
CFW11 0180 T 2	150 (5.91)	250 (9.84)		80 (3.15)
CFW11 0211 T 2				40 (1.57)
CFW11 0105 T 4	100 (3.94)	130 (5.12)		80 (3.15)
CFW11 0142 T 4	150 (5.91)	250 (9.84)		40 (1.57)
CFW11 0180 T 4				80 (3.15)
CFW11 0211 T 4			40 (1.57)	

Tolerance: ±1.0 mm (±0.039 in)

Figure 3.2 - Free spaces for ventilation, above, below, at the front and at the sides of the inverter

3.1.3 Cabinet Mounting

There are two possibilities for mounting the inverter: through the wall mounting or flange mounting (the heatsink is mounted outside the cabinet and the cooling air of the power module is kept outside the enclosure). The following information shall be considered in these cases:

Surface assembly:

- ☑ Provide adequate exhaustion so that the internal cabinet temperature is kept within the allowable operating range of the inverter.
- ☑ The power dissipated by the inverter at its rated condition, as specified in table 8.1 "Dissipated power in Watts - Through the wall mounting".
- ☑ The cooling air flow requirements, as shown in table 3.1.
- ☑ The position and diameter of the mounting holes, according to figure 3.1.

Flange assembly:

- ☑ The losses specified in table 8.1 "Dissipated power in Watts - Flange mounting" will be dissipated inside the cabinet. The remaining losses (power module) will be dissipated through the vents.
- ☑ The inverter securing supports and the hoisting eyes must be removed and repositioned according to the figure 3.3.
- ☑ The portion of the inverter that is located outside the cabinet is rated IP54. Provide an adequate gasket for the cabinet opening to ensure that the enclosure rating is maintained. Example: silicone gasket.
- ☑ Mounting surface opening dimensions and position/diameter of the mounting holes, as shown in figure 3.1.

Table 3.1 - Cooling air flow for frame size E models

Model	CFM	l/s	m ³ /min
CFW11 0142 T 2	138	65	3.9
CFW11 0180 T 2	265	125	7.5
CFW11 0211 T 2			
CFW11 0105 T 4	138	65	3.9
CFW11 0142 T 4	180	95	5.1
CFW11 0180 T 4	265	125	7.5
CFW11 0211 T 4			

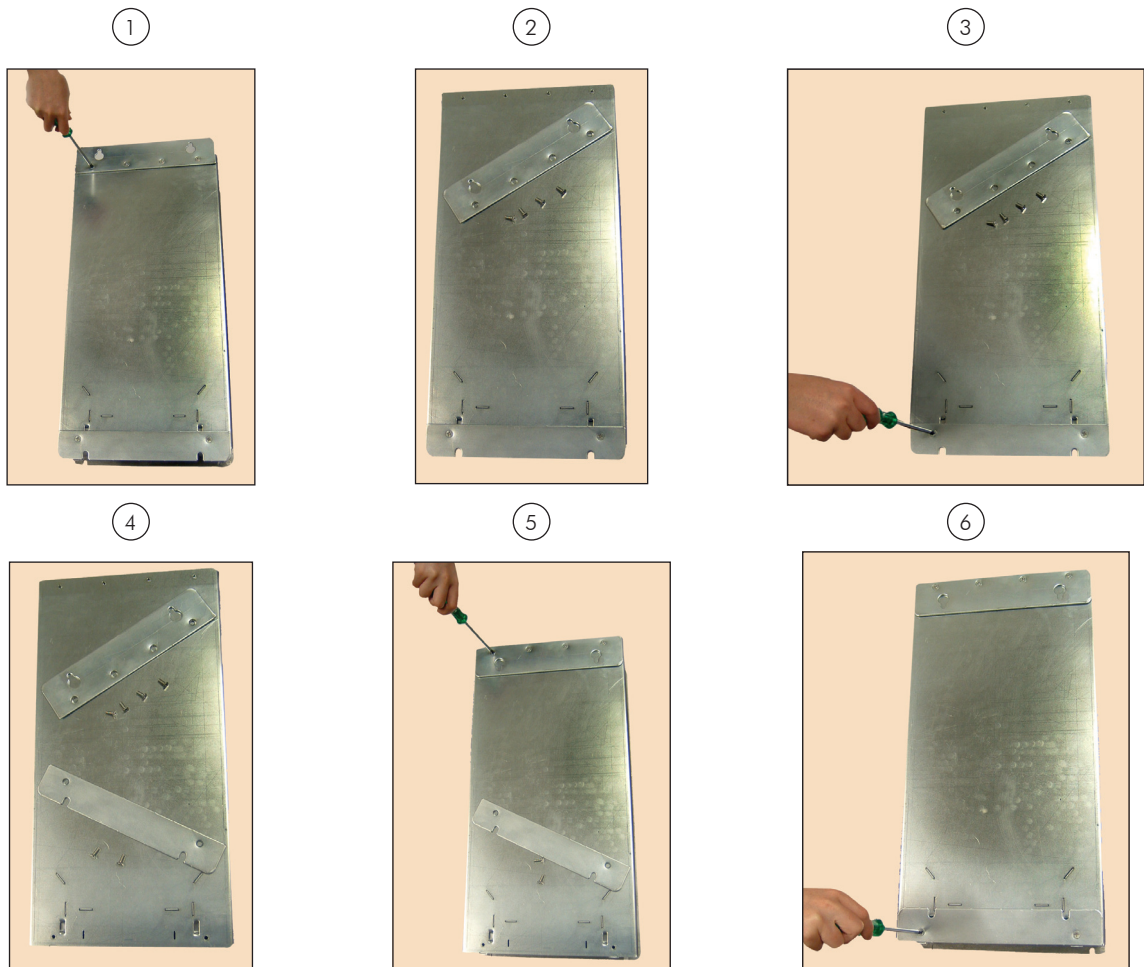

Figure 3.3 - Repositioning the mounting supports

3.1.4 Installation of the Inverter Hoisting Eyes

Two hoisting eyes for the inverter lifting, which are mounted at the inverter sides (rear part), are supplied. By inverting their position, as showed in the figure 3.4, 2 points for hoisting the inverter, which are very useful during the mechanical installation of the inverter, are obtained.

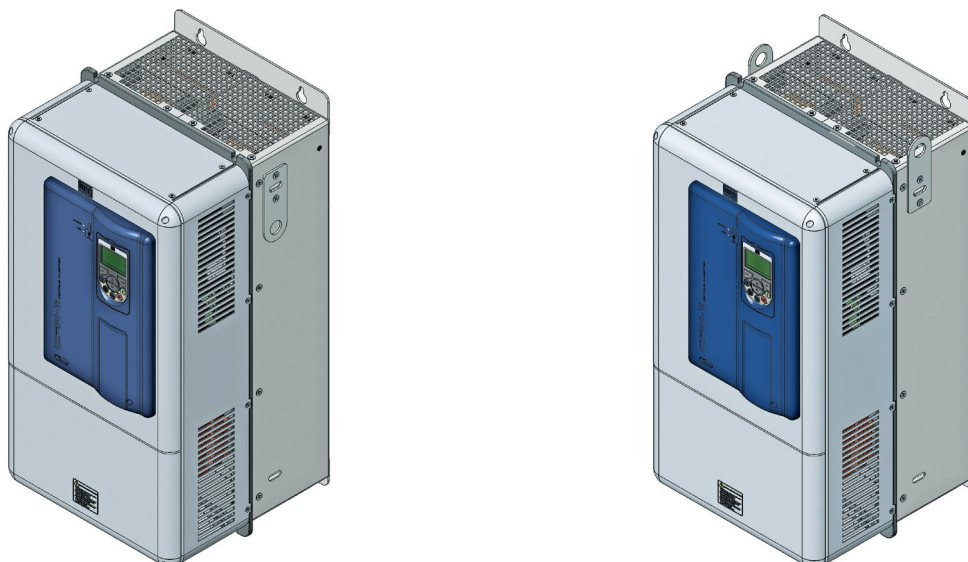

Figure 3.4 - Installation of the inverter hoisting eyes

3.1.5 Installation of the Inverter with Nema1 Kit (Optional, CFW11XXXTXON1) on a Wall

- ☑ Fixing holes position and diameter according to the figure 3.1.
- ☑ External dimensions of the inverter with Nema1 kit according to the section 8.4.
- ☑ Fasten the inverter.
- ☑ Install the Nema1 kit top on the inverter as showed in the figure 3.5 using the 2 M8 screws supplied with the product.

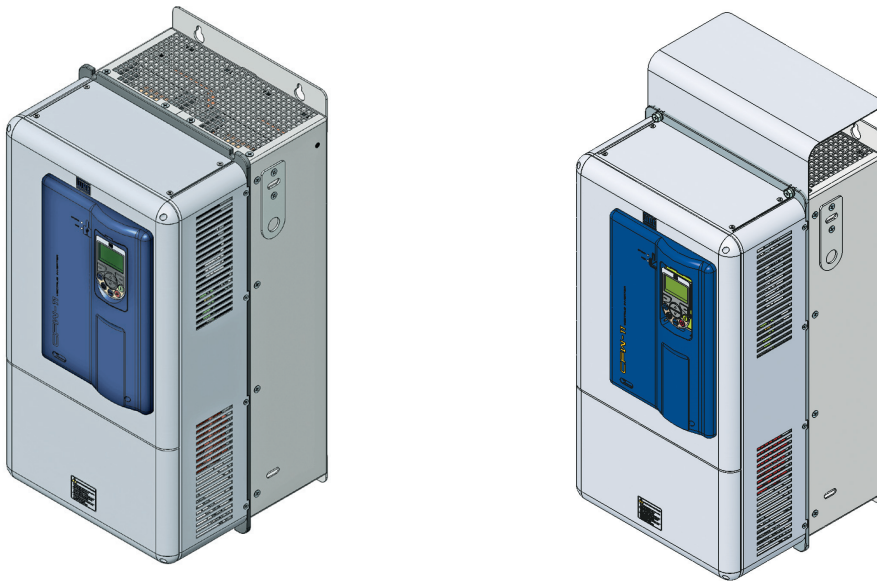

Figure 3.5 - Installation of the Nema1 kit top ("hat")

3.1.6 Access to the Control and Power Terminal Strips

In order to get access to the control terminal strips, the HMI and the cover of the control rack must be removed, as showed in the figure 3.6.



Figure 3.6 - HMI and control rack cover removal

In order to get access to the power terminal block, the bottom front cover must be removed, as showed in the figure 3.7.

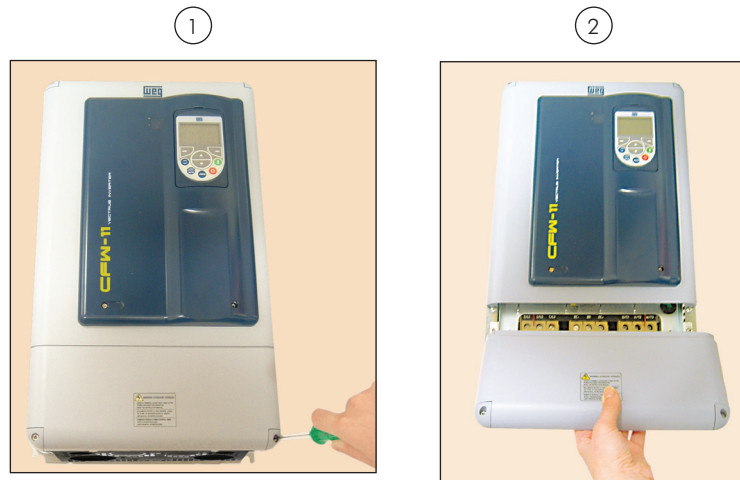

Figure 3.7 - Bottom front cover removal

At the CFW11 0180 T 2 O N1, CFW11 0211 T 2 O N1, CFW11 0180 T 4 O N1 and CFW11 0211 T 4 O N1 inverters (supplied with Nema1 kit), it is also necessary to remove the front cover of the Nema1 kit bottom part in order to be able to execute the power section electric installation – see the figure 3.8.

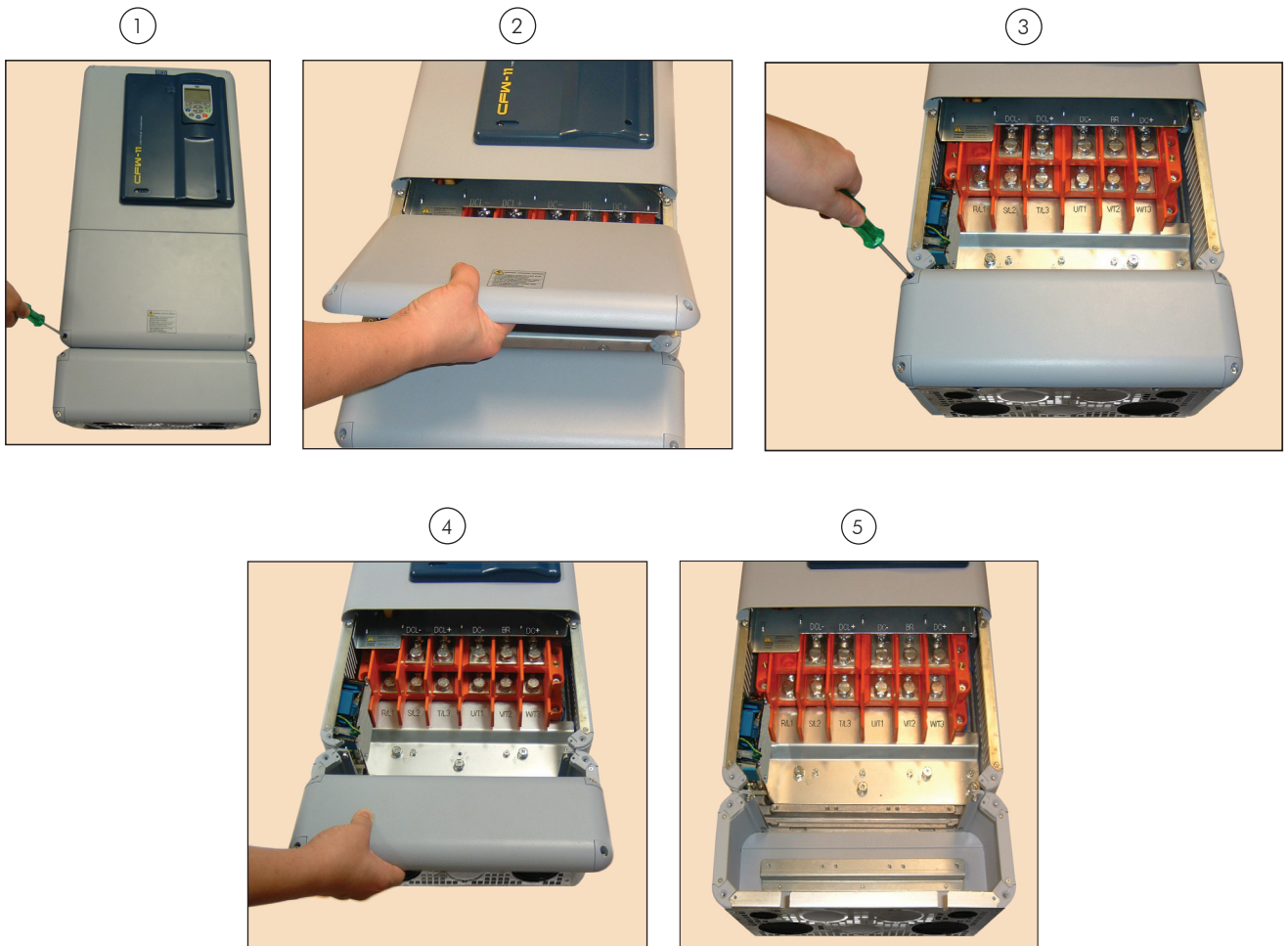

Figure 3.8 - Removal of the Nema1 kit bottom front cover at the CFW11 0180 T 2 O N1, CFW11 0211 T 2 O N1, CFW11 0180 T 4 O N1 and CFW11 0211 T 4 O N1 inverters in order to get access to the power terminal block

3.1.7 Removal of the Cable Passage Plate

When it is not necessary neither IP20 nor Nema1 protection degree, the cable passage plate may be removed in order to make the inverter electric installation easier. Remove the 4 M4 screws, according to the procedure presented in the figure 3.9.

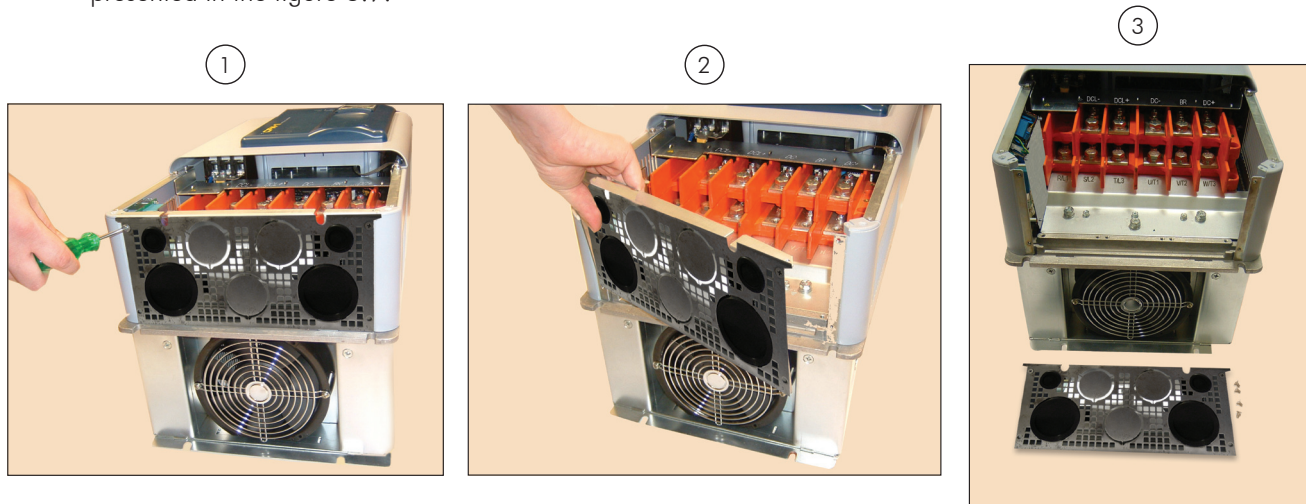

Figure 3.9 - Removal of the cable passage plate

3.1.8 HMI Installation at the Cabinet Door or Command Panel (Remote HMI)

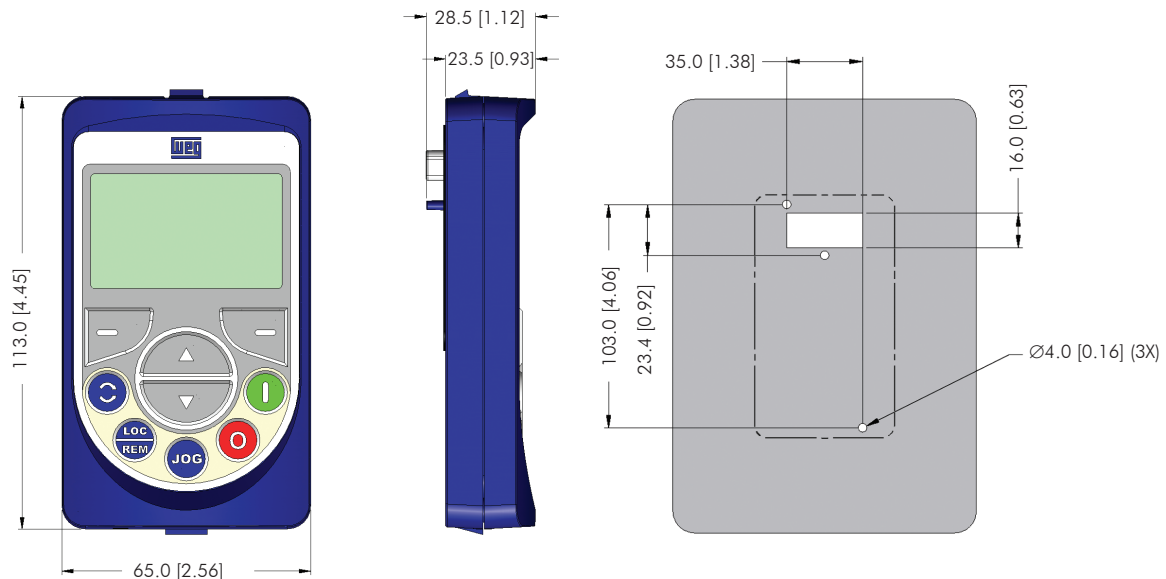

Figure 3.10 - Data for the HMI installation at the cabinet door or command panel – mm [in]

The keypad frame accessory can also be used to fix the HMI, as mentioned in the table 7.2.

3.2 ELECTRICAL INSTALLATION



DANGER!

The following information is merely a guide for proper installation. Comply with applicable local regulations for electrical installations.



DANGER!

Make sure the AC power supply is disconnected before starting the installation.



ATTENTION!

Integral solid state short circuit protection does not provide branch circuit protection. Branch circuit protection must be provided in accordance with applicable local codes.

3.2.1 Identification of the Power and Grounding Terminals

R/L1, S/L2, T/L3: AC power supply.

U/T1, V/T2, W/T3: motor connection.

DC+: this is the positive potential terminal in the DC bus circuit.

BR: braking resistor connection.

DC-: this is the negative potential terminal in the DC bus circuit.

DCL+: positive pole of the rectifier output voltage.

DCL-: negative pole of the rectifier output voltage.

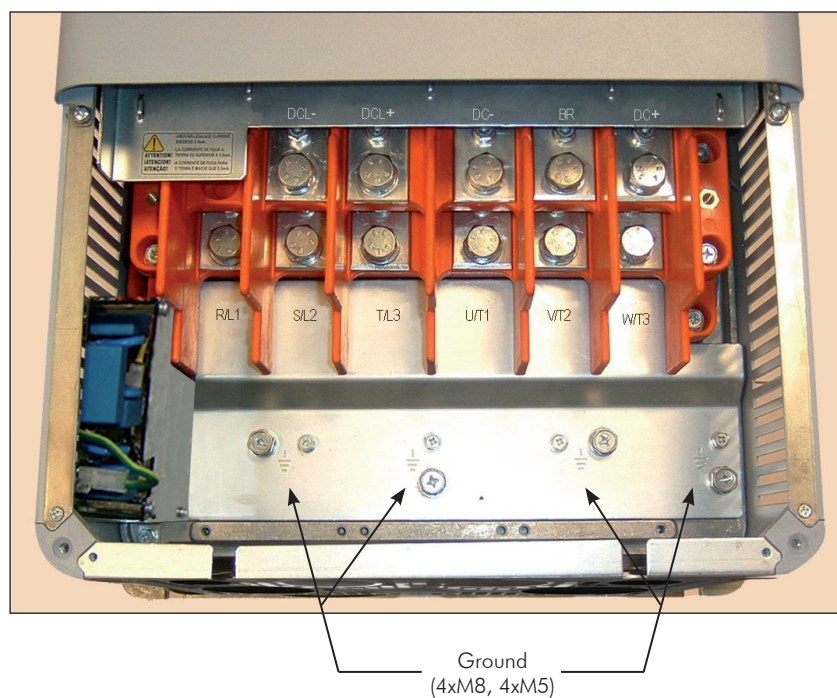

Figure 3.11 - Power terminals and grounding points of the CFW-11 series frame size E models

3.2.2 Power / Grounding Wiring and Fuses



ATTENTION!

Use proper cable lugs for the power and grounding connection cables.



ATTENTION!

Sensitive equipment such as PLCs, temperature controllers, and thermal couples shall be kept at a minimum distance of 0.25 m (9.84 in) from the frequency inverter and from the cables that connect the inverter to the motor.



DANGER!

Improper cable connection:

- The inverter will be damaged in case the input power supply is connected to the output terminals (U/T1, V/T2, or W/T3).
- Check all the connections before powering up the inverter.
- In case of replacing an existing inverter by a CFW-11, check if the installation and wiring is according to the instructions listed in this manual.



ATTENTION!

Residual Current Device (RCD):

- When installing an RCD to guard against electrical shock, only devices with a trip current of 300 mA should be used on the supply side of the inverter.
- Depending on the installation (motor cable length, cable type, multimotor configuration, etc.), the RCD protection may be activated. Contact the RCD manufacturer for selecting the most appropriate device to be used with inverters.



NOTE!

The wire gauge values listed in table 3.2 are merely a guide. Installation conditions and the maximum permitted voltage drop shall be considered for the proper wiring sizing.

Input fuses

- ☑ Use High Speed Fuses at the input for the protection of the inverter rectifier and wiring. Refer to table 3.2 for selecting the appropriate fuse rating (I^2t shall be equal to or less than indicated in table 3.2, consider the cold (and not the fusion) current extinction value).
- ☑ In order to meet UL requirements, use class J fuses at the inverter supply with a current not higher than the values of table 3.2.
- ☑ Optionally, slow blow fuses can be used at the input. They shall be sized for 1.2 x the rated input current of the inverter. In this case, the installation is protected against short-circuit, but not the inverter input rectifier. This may result in major damage to the inverter in the event of an internal component failure.

Table 3.2 - Recommended Wire size/ Fuses - use only copper wire [75 °C (167 °F)]







Model	Frame	Power terminal			Over-load class	Wire size			Fuse [A]	Fuse I ² t [A ² s]
		Terminals	Bolt (wrench/screw head type)	Recommended torque N.m (lbf.in)		mm ²	AWG	Terminals		
CFW11 0142 T 2		R/L1,S/L2,T/L3, U/T1,V/T2,W/T3, DC+,DC-, DCL+,DCL-	M8 (hexagonal phillips screw)	15 (132.75)	HD	50	1/0	Ring tongue terminal	200	39200
					ND	70	2/0			
			M5 and M8 (hexagonal phillips screw)	M5: 3.5 (31.0); M8: 10 (88.5)	HD/ND	35	2			
CFW11 0180 T 2		R/L1,S/L2,T/L3, U/T1,V/T2,W/T3, DC+,DC-, DCL+,DCL-	M10 (hexagonal screw)	30 (265.5)	HD	70 (or 2x25)	2/0 (or 2x4)	Ring tongue terminal	200	218000
					ND	120 (or 2x35)	4/0 (or 2x2)			
			M5 and M8 (hexagonal phillips screw)	M5: 3.5 (31.0); M8: 10 (88.5)	HD/ND	50	1			
CFW11 0211 T 2		R/L1,S/L2,T/L3, U/T1,V/T2,W/T3, DC+,DC-, DCL+,DCL-	M10 (hexagonal screw)	30 (265.5)	HD	120 (or 2x35)	4/0 (or 2x2)	Ring tongue terminal	250	218000
					ND	150 (or 2x50)	300 (or 2x1)			
			M5 and M8 (hexagonal phillips screw)	M5: 3.5 (31.0); M8: 10 (88.5)	HD/ND	70	2/0			
CFW11 0105 T 4 E		R/L1,S/L2,T/L3, U/T1,V/T2,W/T3, DC+,DC-, DCL+,DCL-	M8 (hexagonal phillips screw)	15 (132.75)	HD	35	2	Ring tongue terminal	125	39200
					ND	50	1			
			M5 and M8 (hexagonal phillips screw)	M5: 3.5 (31.0); M8: 10 (88.5)	HD/ND	25	4			
CFW11 0142 T 4		R/L1,S/L2,T/L3, U/T1,V/T2,W/T3, DC+,DC-, DCL+,DCL-	M8 (hexagonal phillips screw)	15 (132.75)	HD	50	1/0	Ring tongue terminal	200	39200
					ND	70	2/0			
			M5 and M8 (hexagonal phillips screw)	M5: 3.5 (31.0); M8: 10 (88.5)	HD/ND	35	2			
CFW11 0180 T 4		R/L1,S/L2,T/L3, U/T1,V/T2,W/T3, DC+,DC-, DCL+,DCL-	M10 (hexagonal screw)	30 (265.5)	HD	70 (or 2x25)	2/0 (or 2x4)	Ring tongue terminal	200	218000
					ND	120 (or 2x35)	4/0 (or 2x2)			
			M5 and M8 (hexagonal phillips screw)	M5: 3.5 (31.0); M8: 10 (88.5)	HD/ND	50	1			
CFW11 0211 T 4		R/L1,S/L2,T/L3, U/T1,V/T2,W/T3, DC+,DC-, DCL+,DCL-	M10 (hexagonal screw)	30 (265.5)	HD	120 (or 2x35)	4/0 (or 2x2)	Ring tongue terminal	250	218000
					ND	150 (or 2x50)	300 (or 2x1)			
			M5 and M8 (hexagonal phillips screw)	M5: 3.5 (31.0); M8: 10 (88.5)	HD/ND	70	2/0			

Table 3.3 (a) - Recommended cable lugs for power connections (cable gauges in mm²)

Wire size [mm ²]	Stud size	Manufacturer	Ring lug, P/N	Crimping (installation) tool P/N	Number of crimps
25	M5	Hollingsworth	RM 25 -5	H 6.500	1
		Tyco	33468	59975-1	1
	M8	Hollingsworth	RM 25-8	H 6.500	1
		Burndy (FCI)	YA3CL	Dieless tool: MY29-3 or Y644 or Y81; Tool+U-die: Y46 or Y35 or Y750 / U3CRT	1
	M10	Tyco	33470	59975-1	1
		Hollingsworth	RM 25-10	H 6.500	1
35	M5	Tyco	33471	59975-1	1
		Hollingsworth	RM 35-5	H 6.500	1
		Burndy (FCI)	YA2CL2	Dieless tool: MY29-3 or Y644 or Y81; Tool+U-die: Y46 or Y35 or Y750 / U2CRT	1
	M8	Tyco	330301	59975-1	1
		Hollingsworth	RM 35-8	H 6.500	1
		Burndy (FCI)	YAC2CL	Dieless tool: MY29-3 or Y644 or Y81; Tool+U-die: Y46 or Y35 or Y750 / U2CRT	1
50	M5	Tyco	322870	59975-1	1
		Hollingsworth	RM 50-5	H 6.500	1
		Burndy (FCI)	YA1CL2	Dieless tool: MY29-3 or Y644 or Y81; Tool+U-die: Y46 or Y35 or Y750 / U1CRT	1
	M8	Tyco	36915	Hand tool: 1490748-1, U-die: 1490413-5 + 1490414-3	1
		Hollingsworth	RM 50-8	H 6.500	1
		Burndy (FCI)	YA1CL	Dieless tool: MY29-3 or Y644 or Y81; Tool+U-die: Y46 or Y35 or Y750 / U1CRT	1
	M10	Tyco	36916	Hand tool: 1490748-1, U-die: 1490413-5 + 1490414-3	1
		Hollingsworth	RM 50-10	H 6.500	1
		Burndy (FCI)	YA1CL4	Dieless tool: MY29-3 or Y644 or Y81; Tool+U-die: Y46 or Y35 or Y750 / U1CRT	1
70	M5	Tyco	36917	Hand tool: 1490748-1, U-die: 1490413-5 + 1490414-3	1
		Hollingsworth	RM 70-5	H 6.500	1
		Burndy (FCI)	YA26L2	Dieless tool: MY29-3 or Y644 or Y81; Tool+U-die: Y46 or Y35 or Y750 / U26RT	1
	M8	Tyco	321869	Hand tool: 1490748-1, U-die: 1490413-6 + 1490414-3	1
		Hollingsworth	RM 70-8	H 6.500	1
		Burndy (FCI)	YA26L	Dieless tool: MY29-3 or Y644 or Y81; Tool+U-die: Y46 or Y35 or Y750 / U26RT	1
	M10	Tyco	321870	Hand tool: 1490748-1, U-die: 1490413-6 + 1490414-3	1
		Hollingsworth	RM 70-10	H 6.500	1
		Burndy (FCI)	YA26L4	Dieless tool: MY29-3 or Y644 or Y81; Tool+U-die: Y46 or Y35 or Y750 / U26RT	1
120	M10	Tyco	321871	Hand tool: 1490748-1, U-die: 1490413-6 + 1490414-3	1
		Hollingsworth	RM120-10	H 6.500	1
		Burndy (FCI)	YA29L4	Dieless tool: MY29-3 or Y644 or Y81; Tool+U-die: Y46 or Y35 or Y750 / U29RT	1
150	M10	Tyco	322252	Hydraulic pump: 1804700-1 (electric) or 1583659-1 (foot pump), 1583662-1 -2 or -3 (1.8 m, 3 m or 6 m)	1
		Hollingsworth	RM150-10	H 6.500	1
		Burndy (FCI)	YA30L24	Dieless tool: MY29-3 or Y644 or Y81; Tool+U-die: Y46 or Y35 or Y750 / U30RT	1
		Tyco	322252	Hydraulic pump: 1804700-1 (electric) or 1583659-1 (foot pump), 1583662-1 -2 or -3 (1.8 m, 3 m or 6 m)	1

Table 3.3 (b) - Recommended cable lugs for power connections (cable gauges in AWG)

Wire size [AWG/kcmil]	Stud size	Manufacturer	Ring lug, P/N	Crimping tool P/N	Number of crimps
4	M5	Hollingsworth	R 410	H 6.500	1
		Burndy (FCI)	YA4CL2	Dieless tool: MY29-3 or Y644 or Y81; Tool+U-die: Y46 or Y35 or Y750 / U4CRT	1
		Tyco	33468	59975-1	1
	M8	Hollingsworth	R 4516	H 6.500	1
		Burndy (FCI)	YA4CL3	Dieless tool: MY29-3 or Y644 or Y81; Tool+U-die: Y46 or Y35 or Y750 / U4CRT	1
		Tyco	33470	59975-1	1
	M10	Hollingsworth	R 438	H 6.500	1
		Burndy (FCI)	YA4CL4	Dieless tool: MY29-3 or Y644 or Y81; Tool+U-die: Y46 or Y35 or Y750 / U4CRT	1
		Tyco	33471	59975-1	1
2	M5	Hollingsworth	R 210	H 6.500	1
		Burndy (FCI)	YA2CL2	Dieless tool: MY29-3 or Y644 or Y81; Tool+U-die: Y46 or Y35 or Y750 / U2CRT	1
		Tyco	330301	59975-1	1
	M8	Hollingsworth	R 2516	H 6.500	1
		Burndy (FCI)	YA2CL	Dieless tool: MY29-3 or Y644 or Y81; Tool+U-die: Y46 or Y35 or Y750 / U2CRT	1
		Tyco	322870	59975-1	1
1	M5	Hollingsworth	R 110	H 6.500	1
		Burndy (FCI)	YA1CL2	Dieless tool: MY29-3 or Y644 or Y81; Tool+U-die: Y46 or Y35 or Y750 / U1CRT	1
		Tyco	330301	59975-1	1
	M8	Hollingsworth	R 1516	H 6.500	1
		Burndy (FCI)	YA1CL	Dieless tool: MY29-3 or Y644 or Y81; Tool+U-die: Y46 or Y35 or Y750 / U1CRT	1
		Tyco	322870	59975-1	1
	M10	Hollingsworth	R 138	H 6.500	1
		Burndy (FCI)	YA1CL4	Dieless tool: MY29-3 or Y644 or Y81; Tool+U-die: Y46 or Y35 or Y750 / U1CRT	1
		Tyco	321600	59975-1	1
1/0	M8	Hollingsworth	R 10516	H 6.500	1
		Burndy (FCI)	YA25L	Dieless tool: MY29-3 or Y644 or Y81; Tool+U-die: Y46 or Y35 or Y750 / U25RT	1
		Tyco	36916	Hand tool: 1490748-1, U-die: 1490413-5 + 1490414-3	1
2/0	M5	Hollingsworth	R 2010	H 6.500	1
		Burndy (FCI)	YA26L2	Dieless tool: MY29-3 or Y644 or Y81; Tool+U-die: Y46 or Y35 or Y750 / U26RT	1
		Tyco	321869	Hand tool: 1490748-1, U-die: 1490413-6 + 1490414-3	1
	M8	Hollingsworth	R 20516	H 6.500	1
		Burndy (FCI)	YA26L	Dieless tool: MY29-3 or Y644 or Y81; Tool+U-die: Y46 or Y35 or Y750 / U26RT	1
		Tyco	321870	Hand tool: 1490748-1, U-die: 1490413-6 + 1490414-3	1
	M10	Hollingsworth	R 2038	H 6.500	1
		Burndy (FCI)	YA26L4	Dieless tool: MY29-3 or Y644 or Y81; Tool+U-die: Y46 or Y35 or Y750 / U26RT	1
		Tyco	321871	Hand tool: 1490748-1, U-die: 1490413-6 + 1490414-3	1
4/0	M10	Hollingsworth	R 4038	H 6.500	1
		Burndy (FCI)	YA28L4	Dieless tool: MY29-3 or Y644 or Y81; Tool+U-die: Y46 or Y35 or Y750 / U28RT	1
		Tyco	36932	Hand tool: 1490748-1, U-die: 1490413-8 + 1490414-3	1
300	M10	Hollingsworth	R30038	H 6.500	1
		Burndy (FCI)	YA30L24	Dieless tool: MY29-3 or Y644 or Y81; Tool+U-die: Y46 or Y35 or Y750 / U30RT	1
		Tyco	322252	Hydraulic pump: 1804700-1 (electric) or 1583659-1 (foot pump), 1583662-1 -2 or -3 (1.8 m, 3 m or 6 m)	1

3.2.3 Power Connections

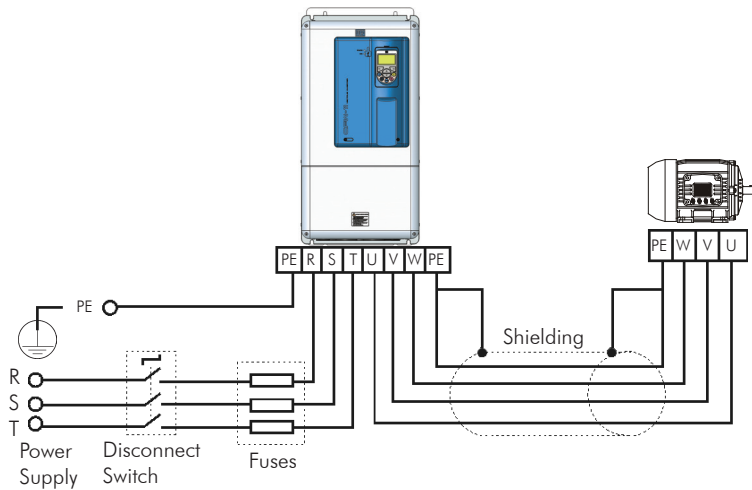

Figure 3.12 - Power and grounding connections

3.2.3.1 Input Connections

3



DANGER!

Provide a disconnect device for the input power supply of the inverter. This device shall disconnect the input power supply for the inverter when needed (for instance, during servicing).



ATTENTION!

A contactor or another device that frequently disconnects and reapplies the AC supply to the inverter in order to start and stop the motor may cause damage to the inverter power section. The drive is designed to use control signals for starting and stopping the motor. If used for that purpose, the input device must not exceed one operation per minute otherwise the inverter may be damaged.



ATTENTION!

The power supply that feeds the inverter shall have a grounded neutral. In case of IT networks, follow the instructions described in item 3.2.3.1.1.



NOTE!

The input power supply voltage shall be compatible with the inverter rated voltage.



NOTE!

Power factor correction capacitors are not needed at the inverter input (R, S, T) and shall not be installed at the output of the inverter (U, V, W).

AC power supply considerations

- ☑ The CFW-11 inverters are suitable for use on a circuit capable of delivering up to a maximum of 100,000 A_{rms} symmetrical (230 V / 480 V).

3.2.3.1.1 IT Networks



ATTENTION!

In order to be able to use the frame size E CFW-11 inverter in IT networks (neutral conductor not grounded or grounded via a high ohmic value resistor) or in corner-grounded delta systems, it is necessary to remove the RFI filter capacitor and the MOV connected to the ground by changing the position of the J1 jumper on the PRT1 board from \oplus (XE1) to "NC", according to the figure 3.13.

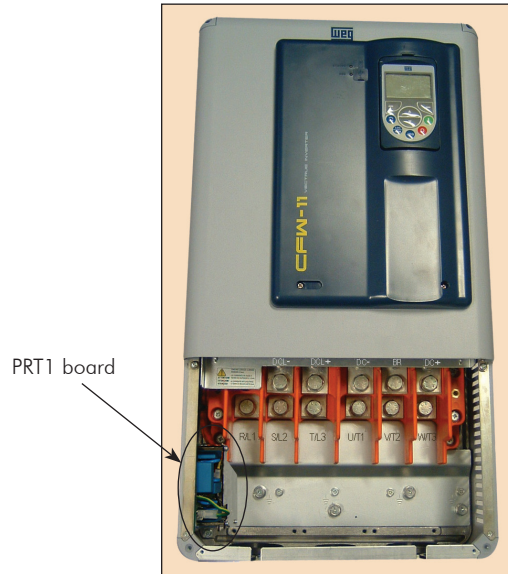

(a) Location of the PRT1 board (inverter without the bottom front cover)

①



②



③

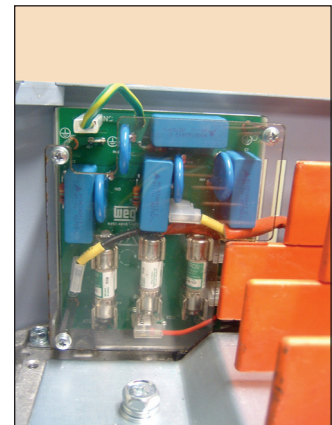

(b) Procedure for disconnecting the RFI filter and the MOV connected to the ground – necessary for using the inverter in IT or corner-grounded delta networks

Figure 3.13 (a) and (b) - Location of the PRT1 board and procedure for disconnecting the RFI filter and the MOV connected to the ground – necessary for using the inverter in IT or corner-grounded delta networks

3.2.3.1.2 Command Fuses

- ☑ Besides the RFI filter capacitors and the MOV's, the PRT1 board also has 3 fuses for protecting the inverter command circuit.
- ☑ The PRT1 board location is presented in the figure 3.13 (a).
- ☑ The location of the PRT1 fuses is presented in the figure 3.13 (b).
- ☑ See below the specification of the used command fuses:
 - Slow blow fuse 0.5 A / 600 V;
 - Manufacturer: Cooper Bussmann;
 - Part number: FNQ-R-1/2;
 - WEG part number: 10411493.

Consider the following items for the use of protection devices on the supply side of the inverter such as residual current devices or isolation monitors:

- The detection of a phase-to-ground short-circuit or an insulation fault shall be processed by the user, i.e., the user shall decide whether to indicate the fault and/or block the inverter operation.
- Contact the RCD manufacturer for selecting the most appropriate device to be used with inverters in order to avoid nuisance tripping due to the high frequency leakage currents that flow through the leakage capacitances of the inverter, cable, and motor system to the ground.

3.2.3.2 Dynamic Braking



ATTENTION!

For the CFW-11 frame size E models, only those with the DB option (CFW11XXXXXODB) have the braking IGBT incorporated to the product.

The braking torque that can be obtained from the frequency inverter without braking resistors varies from 10 % to 35 % of the motor rated torque.

Braking resistors shall be used to obtain higher braking torques. In this case, the energy regenerated in excess is dissipated in a resistor mounted externally to the inverter.

This type of braking is used in cases where short deceleration times are desired or when high inertia loads are driven.

For the vector control mode, there is the possibility of using the "Optimal Braking", eliminating in many cases the need of dynamic braking use.



NOTE!

Set P0151 and P0185 to their maximum values (400 V or 800 V) when using dynamic braking.

3.2.3.2.1 Sizing the Braking Resistor

The following application data shall be considered for the adequate sizing of the braking resistor:

- Desired deceleration time;
- Load inertia;
- Braking duty cycle.

In any case, the effective current value and the maximum braking current value presented in table 3.4 shall be respected.

The maximum braking current defines the minimum braking resistor value in ohms.

The DC bus voltage level for the activation of the dynamic braking function is defined by parameter P0153 (dynamic braking level).

The power of the braking resistor is a function of the deceleration time, the load inertia, and the load torque.

For most applications, a braking resistor with the value in ohms indicated in table 3.4 and the power of 20 % of the rated driven motor power. Use wire type resistors in a ceramic support with adequate insulation voltage and capable of withstanding high instantaneous power with respect to rated power. For critical applications with very short deceleration times and high inertia loads (ex.: centrifuges) or short duration cycles, consult WEG for the adequate sizing of the braking resistor.

Table 3.4 - Dynamic braking specifications

Inverter model	Maximum braking current (I_{max}) [A]	Maximum braking power (peak value) (P_{max}) ⁽²⁾ [kW]	Effective braking current ($I_{effective}$) ⁽¹⁾ [A]	Dissipated power (mean value) in the braking resistor (P_R) ⁽²⁾ [kW]	Recommended resistor [Ω]	Power wire size (terminals DC+ and BR) ⁽³⁾ [mm ² (AWG)]
CFW11 0142 T 2 \circ DB	266.7	106.7	142.0	30.2	1.5	70 (2/0) or 2x 25 (2x 4)
CFW11 0180 T 2 \circ DB	266.7	106.7	180.0	48.6	1.5	120 (4/0) or 2x 35 (2x 2)
CFW11 0211 T 4 \circ DB	333.3	133.3	211.0	53.4	1.2	150 (300) or 2x 50 (2x 1)
CFW11 0105 T 4 \circ DB	186.0	148.8	105.0	47.4	4.3	50 (1)
CFW11 0142 T 4 \circ DB	266.7	213.3	142.0	60.5	3.0	70 (2/0) or 2x 25 (2x 4)
CFW11 0180 T 4 \circ DB	266.7	213.3	180.0	97.2	3.0	120 (4/0) or 2x 35 (2x 2)
CFW11 0211 T 4 \circ DB	363.6	290.9	191.7	80.8	2.2	120 (250) or 2x 50 (2x 1)

(1) The effective braking current presented is just an indicative value, because it depends on the braking duty cycle. The effective braking current can be obtained from the equation below, where t_{br} is given in minutes and corresponds to the sum of all braking times during the most severe cycle of 5 (five) minutes.

$$I_{effective} = I_{max} \times \sqrt{\frac{t_{br}}{5}}$$

- (2) The P_{max} and P_R values (maximum and mean power of the braking resistor respectively) presented are valid for the recommended resistors and for the effective braking currents presented in table 3.4. The resistor power shall be changed according to the braking duty cycle.
- (3) For specifications on the recommended terminal type (bolt and tightening torque) for the connection of the braking resistor (terminals DC+ and BR), refer to the DC+ terminal specification at the table 3.2.

3.2.3.2.2 Installation of the Braking Resistor

Install the braking resistor between the power terminals DC+ and BR.

Use twisted cable for the connection. Separate these cables from the signal and control cables. Size the cables according to the application, respecting the maximum and effective currents.

If the braking resistor is installed inside the inverter cabinet, consider its additional dissipated energy when sizing the cabinet ventilation.

Set parameter P0154 with the resistor value in ohms and parameter P0155 with the maximum resistor power in kW.

 **DANGER!** The inverter has an adjustable thermal protection for the braking resistor. The braking resistor and the braking transistor may damage if parameters P0153, P0154, and P0155 are not properly set or if the input voltage surpasses the maximum permitted value.

The thermal protection offered by the inverter, when properly set, allows the protection of the resistor in case of overload; however, this protection is not guaranteed in case of braking circuitry failure. In order to avoid any damage to the resistor or risk of fire, install a thermal relay in series with the resistor and/or a thermostat in contact with the resistor body to disconnect the input power supply of the inverter, as presented in figure 3.14.

3

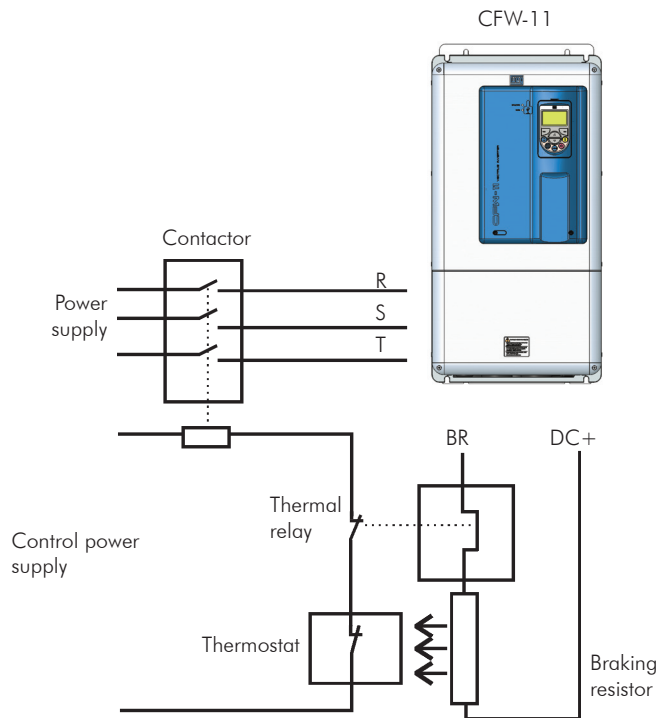



Figure 3.14 - Braking resistor connection

 **NOTE!** DC current flows through the thermal relay bimetal strip during braking.

3.2.3.3 Output Connections



ATTENTION!

The inverter has an electronic motor overload protection that shall be adjusted according to the driven motor. When several motors are connected to the same inverter, install individual overload relays for each motor.



ATTENTION!

The motor overload protection available at the CFW-11 is in accordance with the IEC60947-4-2 and UL508C standards.

Important considerations for the UL508C:

- Trip current equal to 1.25 times the motor rated current (P0401) adjusted in the oriented start-up menu.
- The parameter P0159 maximum setting (Motor Thermal Class) is 3 (Class 20).
- The parameter P0398 maximum setting (Motor Service Factor) is 1.15.



ATTENTION!

If a disconnect switch or a contactor is installed between the inverter and the motor, never operate them with a spinning motor or with voltage at the inverter output.

The characteristics of the cable used for the inverter and motor interconnection, as well as the physical location are extremely important to avoid electromagnetic interference in other equipment and to not affect the life cycle of motor windings and motor bearings controlled by inverters.

Recommendations for the motor cables:

Unshielded Cables:

- Can be used when it is not necessary to meet the European directive of electromagnetic compatibility (89/336/EEC).
- Keep motor cables away from other cables (signal cables, sensor cables, control cables, etc.), according to table 3.5.
- The emission of the cables may be reduced by installing them inside a metal conduit, which shall be grounded at both ends.
- Connect a fourth cable between the motor ground and the inverter ground.

Note:

The magnetic field created by the current circulation in these cables may induce current in close metal pieces, heat them, and cause additional electrical losses. Therefore, keep the 3 (three) cables (U, V, W) always together.

Shielded Cables:

- Are mandatory when the electromagnetic compatibility directive (89/336/EEC) shall be met, as defined by the standard EN 61800-3 "Adjustable Speed Electrical Power Drive Systems". These cables act mainly by reducing the irradiated emission in the radio-frequency range.
- In reference to the type and details of installation, follow the recommendations of IEC 60034-25 "Guide for Design and Performance of Cage Induction Motors Specifically Designed for Converter Supply" – refer to a summary in figure 3.15. Refer to the standard for further details and eventual modifications related to new revisions.

- ☑ Keep motor cables away from other cables (signal cables, sensor cables, control cables, etc.), according to table 3.5.
- ☑ The grounding system shall be well interconnected among the several installation locations such as the grounding points of the motor and the inverter. Voltage difference or impedance between the several points may cause the circulation of leakage currents among the equipment connected to the ground, resulting in electromagnetic interference problems.

Table 3.5 - Minimum separation distance between motor cables and all other cables

Cable length	Minimum separation distance
≤ 30 m (100 ft)	≥ 10 cm (3.94 in)
> 30 m (100 ft)	≥ 25 cm (9.84 in)

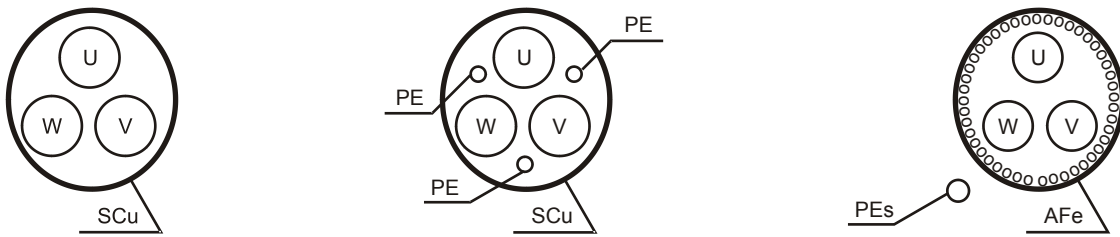

Symmetrical shielded cables: three concentric conductors with or without a ground conductor, symmetrically manufactured, with an external shield of copper or aluminum.

Notes:

- (1) SCu = copper or aluminum external shielding.
- (2) AFe = steel or galvanized iron.
- (3) PE = ground conductor.
- (4) Cable shielding shall be grounded at both ends (inverter and motor). Use 360° connections for a low impedance to high-frequencies. Refer to figure 3.16.
- (5) For using the shield as a protective ground, it shall have at least 50 % of the power cables conductivity. Otherwise, add an external ground conductor and use the shield as an EMC protection.
- (6) Shielding conductivity at high-frequencies shall be at least 10 % of the power cables conductivity.

Figure 3.15 - Motor connection cables recommended by IEC 60034-25

- ☑ Connection of the motor cable shield to ground: Make a connection with low impedance for high frequencies. Example in the figure 3.16. In inverters without the Nema1 kit, connect the motor cable shield to the ground in a similar mode, with the clamp at the inverter inner part, according to the figure 3.16.

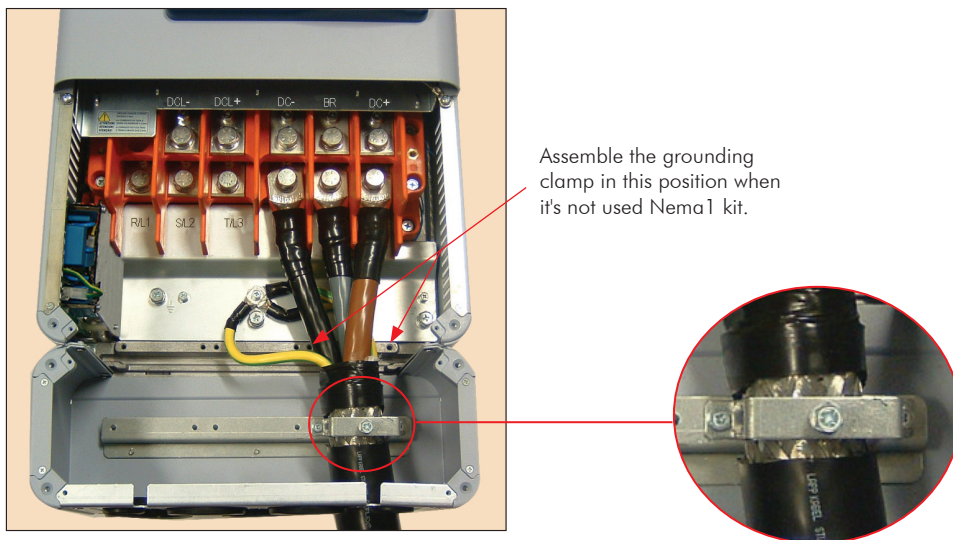

Figure 3.16 - Example of the motor cable shield connection at the inner part of the Nema1 kit supplied with the product

3.2.4 Grounding Connections



DANGER!

Do not share the grounding wiring with other equipment that operate with high currents (ex.: high power motors, soldering machines, etc.). When installing several inverters, follow the procedures presented in figure 3.17 for the grounding connection.



ATTENTION!

The neutral conductor of the network shall be solidly grounded; however, this conductor shall not be used to ground the inverter.



DANGER!

The inverter shall be connected to a Protective Ground (PE).

Observe the following:

- Minimum wire gauge for grounding connection is provided in table 3.2. Conform to local regulations and/or electrical codes in case a different wire gauge is required.
- Connect the inverter grounding connections to a ground bus bar, to a single ground point, or to a common grounding point (impedance $\leq 10 \Omega$).
- To comply with IEC 61800-5-1 standard, connect the inverter to the ground by using a single conductor copper cable with a minimum wire gauge of 10 mm², since the leakage current is greater than 3.5 mA AC.

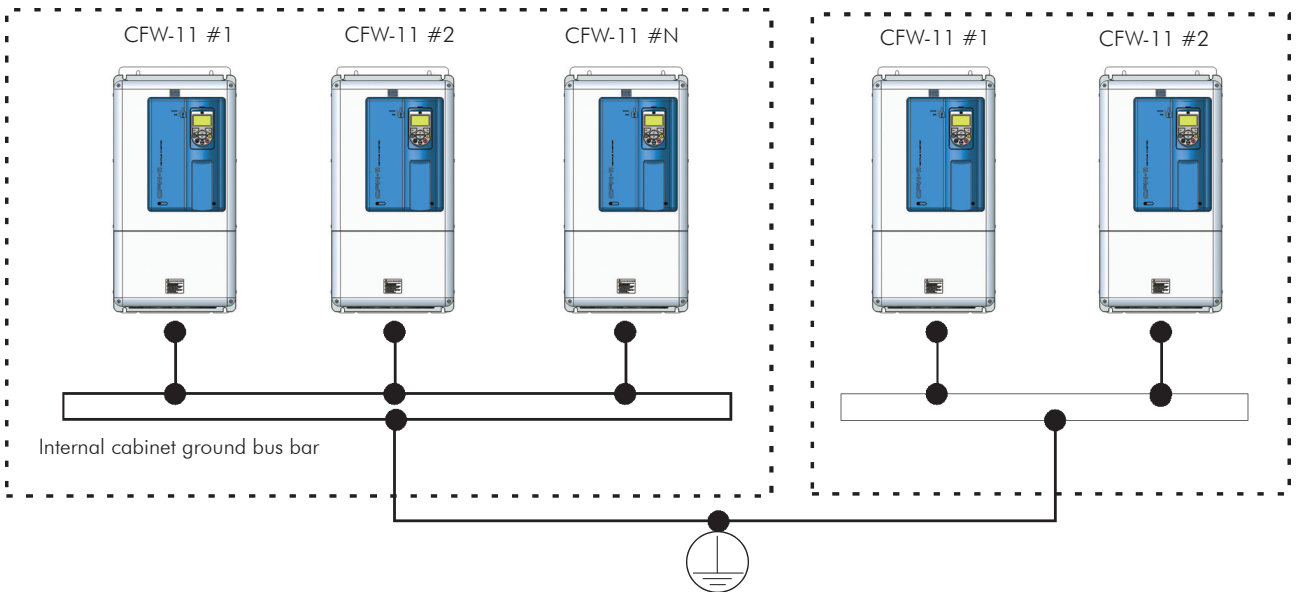

Figure 3.17 - Grounding connections with multiple inverters

3.2.5 Control Connections

The control connections (analog inputs/outputs, digital inputs/outputs), shall be performed in connector XC1 of the CC11 control board.

Functions and typical connections are presented in figures 3.18 (a) and (b).

Connector XC1		Factory Default Function	Specifications
1	+REF	Positive reference for potentiometer	Output voltage: +5.4 V, ±5 % Maximum output current: 2 mA
2	AI1+	Analog input #1: Speed reference (remote)	Differential Resolution: 12 bits Signal: 0 to 10 V (R _{IN} =400 kΩ) / 0 to 20 mA / 4 to 20 mA (R _{IN} =500 Ω) Maximum voltage: ±30 V
3	AI1-		
4	REF-	Negative reference for potentiometer	Output voltage: -4.7 V, ±5 % Maximum output current: 2 mA
5	AI2+	Analog input #2: No function	Differential Resolution: 11 bits + signal Signal: 0 to ±10 V (R _{IN} =400 kΩ) / 0 to 20 mA / 4 to 20 mA (R _{IN} =500 Ω) Maximum voltage: ±30 V
6	AI2-		
7	AO1	Analog output #1: Speed	Galvanic Isolation Resolution: 11 bits Signal: 0 to 10 V (R _L ≥ 10 kΩ) / 0 to 20 mA / 4 to 20 mA (R _L ≤ 500 Ω) Protected against short-circuit.
8	AGND (24 V)	Reference (0 V) for the analog outputs	Connected to the ground (frame) through impedance: 940 Ω resistor in parallel with a 22 nF capacitor.
9	AO2	Analog output #2: Motor current	Galvanic Isolation Resolution: 11 bits Signal: 0 to 10 V (R _L ≥ 10 kΩ) / 0 to 20 mA / 4 to 20 mA (R _L ≤ 500 Ω) Protected against short-circuit.
10	AGND (24 V)	Reference (0 V) for the analog outputs	Connected to the ground (frame) through impedance: 940 Ω resistor in parallel with a 22 nF capacitor.
11	DGND*	Reference (0 V) for the 24 Vdc power supply	Connected to the ground (frame) through impedance: 940 Ω resistor in parallel with a 22 nF capacitor.
12	COM	Common point of the digital inputs	
13	24 Vdc	24 Vdc power supply	24 Vdc power supply, ±8 %. Capacity: 500 mA. Note: In the models with the 24 Vdc external control power supply (CFW11XXXXXOW) the terminal 13 of XC1 becomes an input, i.e., the user must connect a 24 V power supply for the inverter (refer to the section 7.1.4 for more details). In all the other models this terminal is an output, i.e., the user has a 24 Vdc power supply available there.
14	COM	Common point of the digital inputs	
15	DI1	Digital input #1: Start / Stop	6 isolated digital inputs High level ≥ 18 V Low level ≤ 3 V Maximum input voltage = 30 V Input current: 11 mA @ 24 Vdc
16	DI2	Digital input #2: Direction of rotation (remote)	
17	DI3	Digital input #3: No function	
18	DI4	Digital input #4: No function	
19	DI5	Digital input #5: Jog (remote)	
20	DI6	Digital input #6: 2 nd ramp	
21	NC1	Digital output #1 DO1 (RL1):	Contact rating: Maximum voltage: 240 Vac Maximum current: 1 A NC - Normally closed contact; C - Common; NO - Normally open contact.
22	C1	No fault	
23	NO1		
24	NC2	Digital output #2 DO2 (RL2):	
25	C2	N > N _x - Speed > P0288	
26	NO2		
27	NC3	Digital output #3 DO3 (RL3):	
28	C3	N* > N _x - Speed reference > P0288	
29	NO3		

Figure 3.18 (a) - Signals at connector XC1 - Digital inputs working as 'Active High'

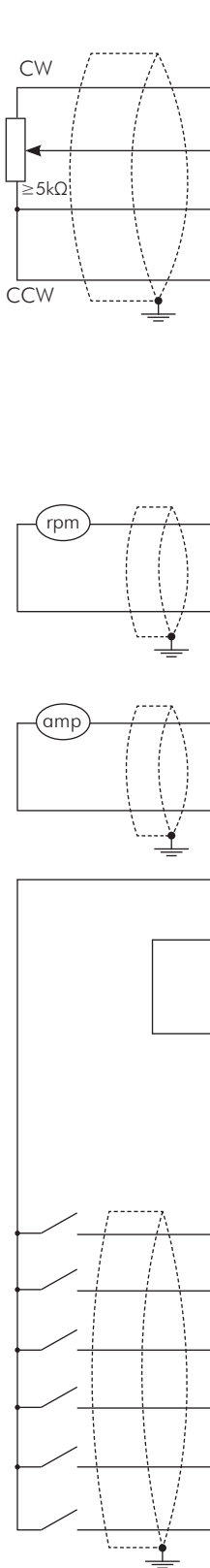

Connector XC1		Factory Default Function	Specifications
1	+REF	Positive reference for potentiometer	Output voltage: +5.4 V, ±5 % Maximum output current: 2 mA
2	AI1 +	Analog input #1: Speed reference (remote)	Differential Resolution: 12 bits Signal: 0 to 10 V ($R_{IN} = 400\text{ k}\Omega$) / 0 to 20 mA / 4 to 20 mA ($R_{IN} = 500\ \Omega$) Maximum voltage: ±30 V
3	AI1 -		
4	REF-	Negative reference for potentiometer	Output voltage: -4.7 V, ±5 % Maximum output current: 2 mA
5	AI2+	Analog input #2: No function	Differential Resolution: 11 bits + signal Signal: 0 to ±10 V ($R_{IN} = 400\text{ k}\Omega$) / 0 to 20 mA / 4 to 20 mA ($R_{IN} = 500\ \Omega$) Maximum voltage: ±30 V
6	AI2-		
7	AO1	Analog output #1: Speed	Galvanic Isolation Resolution: 11 bits Signal: 0 to 10 V ($R_L \geq 10\text{ k}\Omega$) / 0 to 20 mA / 4 to 20 mA ($R_L \leq 500\ \Omega$) Protected against short-circuit.
8	AGND (24 V)	Reference (0 V) for the analog outputs	Connected to the ground (frame) through impedance: 940 Ω resistor in parallel with a 22 nF capacitor.
9	AO2	Analog output #2: Motor current	Galvanic Isolation Resolution: 11 bits Signal: 0 to 10 V ($R_L \geq 10\text{ k}\Omega$) / 0 to 20 mA / 4 to 20 mA ($R_L \leq 500\ \Omega$) Protected against short-circuit.
10	AGND (24 V)	Reference (0 V) for the analog outputs	Connected to the ground (frame) through impedance: 940 Ω resistor in parallel with a 22 nF capacitor.
11	DGND*	Reference (0 V) for the 24 Vdc power supply	Connected to the ground (frame) through impedance: 940 Ω resistor in parallel with a 22 nF capacitor.
12	COM	Common point of the digital inputs	
13	24 Vdc	24 Vdc power supply	24 Vdc power supply, ±8 %. Capacity: 500 mA. Note: In the models with the 24 Vdc external control power supply (CFW11XXXXXOW) the terminal 13 of XC1 becomes an input, i.e., the user must connect a 24 V power supply for the inverter (refer to the section 7.1.4 for more details). In all the other models this terminal is an output, i.e., the user has a 24 Vdc power supply available there.
14	COM	Common point of the digital inputs	
15	DI1	Digital input #1: Start / Stop	6 isolated digital inputs High level $\geq 18\text{ V}$ Low level $\leq 3\text{ V}$ Input voltage $\leq 30\text{ V}$ Input current: 11 mA @ 24 Vdc
16	DI2	Digital input #2: Direction of rotation (remote)	
17	DI3	Digital input #3: No function	
18	DI4	Digital input #4: No function	
19	DI5	Digital input #5: Jog (remote)	
20	DI6	Digital input #6: 2 nd ramp	
21	NC1	Digital output #1 DO1 (RL1): No fault	Contact rating: Maximum voltage: 240 Vac Maximum current: 1 A NC - Normally closed contact; C - Common; NO - Normally open contact.
22	C1		
23	NO1		
24	NC2	Digital output #2 DO2 (RL2): $N > N_x$ - Speed > P0288	
25	C2		
26	NO2		
27	NC3	Digital output #3 DO3 (RL3): $N^* > N_x$ - Speed reference > P0288	
28	C3		
29	NO3		

Figure 3.18 (b) - Signals at connector XC1 - Digital inputs working as 'Active Low'



NOTE!

Remove the jumper between XC1:11 and 12 and install it between XC1:12 and 13 to use the digital inputs as 'Active Low'.

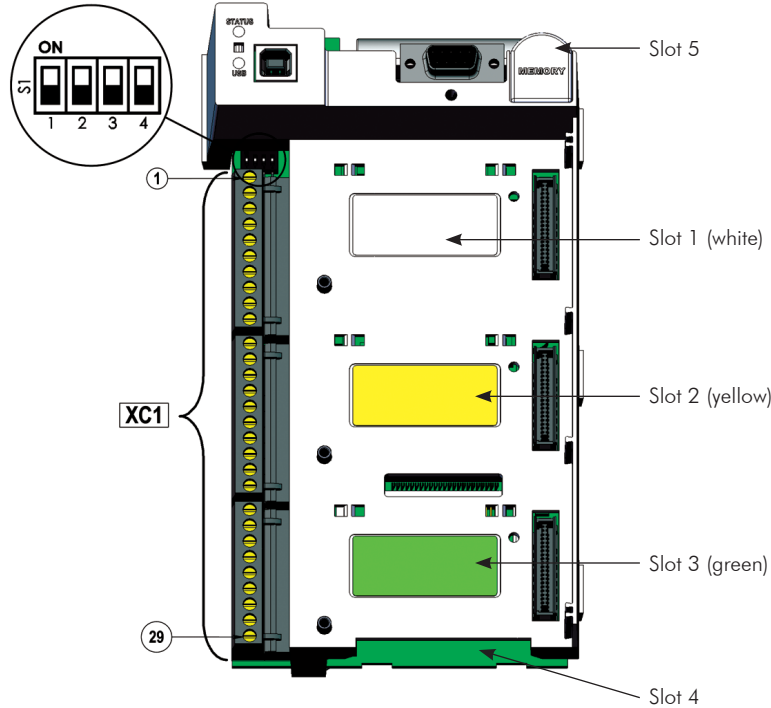

Figure 3.19 - Connector XC1 and DIP-switches for selecting the signal type of the analog inputs and outputs

The analog inputs and outputs are factory set to operate in the range from 0 to 10 V; this setting may be changed by using DIP-switch S1.

Table 3.6 - DIP-switches configuration for the selection of the signal type for the analog inputs and outputs

Signal	Factory Default Function	DIP-switch	Selection	Factory Setting
AI1	Speed Reference (remote)	S1.4	OFF: 0 to 10 V (factory setting) ON: 4 to 20 mA / 0 to 20 mA	OFF
AI2	No Function	S1.3	OFF: 0 to ±10 V (factory setting) ON: 4 to 20 mA / 0 to 20 mA	OFF
AO1	Speed	S1.2	OFF: 4 to 20 mA / 0 to 20 mA ON: 0 to 10 V (factory setting)	ON
AO2	Motor Current	S1.1	OFF: 4 to 20 mA / 0 to 20 mA ON: 0 to 10 V (factory setting)	ON

Parameters related to the analog inputs and outputs (AI1, AI2, AO1, and AO2) shall be programmed according to the DIP-switches settings and desired values.

Follow instructions below for the proper installation of the control wiring:

- 1) Wire gauge: 0.5 mm² (20 AWG) to 1.5 mm² (14 AWG);
- 2) Maximum tightening torque: 0.50 N.m (4.50 lbf.in);
- 3) Use shielded cables for the connections in XC1 and run the cables separated from the remaining circuits (power, 110 V / 220 Vac control, etc.), as presented in table 3.7. If control wiring must cross other cables (power cables for instance), make it cross perpendicular to the wiring and provide a minimum separation of 5 cm (1.9 in) at the crossing point.

Table 3.7 - Minimum separation distances between wiring

Cable Length	Minimum Separation Distance
≤ 30 m (100 ft)	≥ 10 cm (3.94 in)
> 30 m (100 ft)	≥ 25 cm (9.84 in)

4) The adequate connection of the cable shield is shown in figure 3.20. Figure 3.21 shows how to connect the cable shield to the ground.

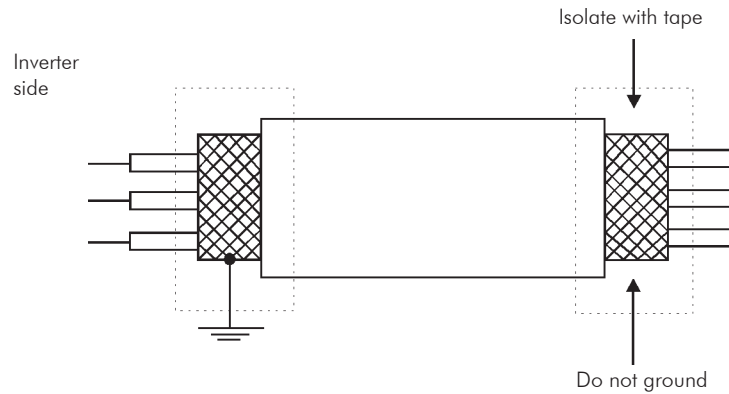

Figure 3.20 - Shield connection

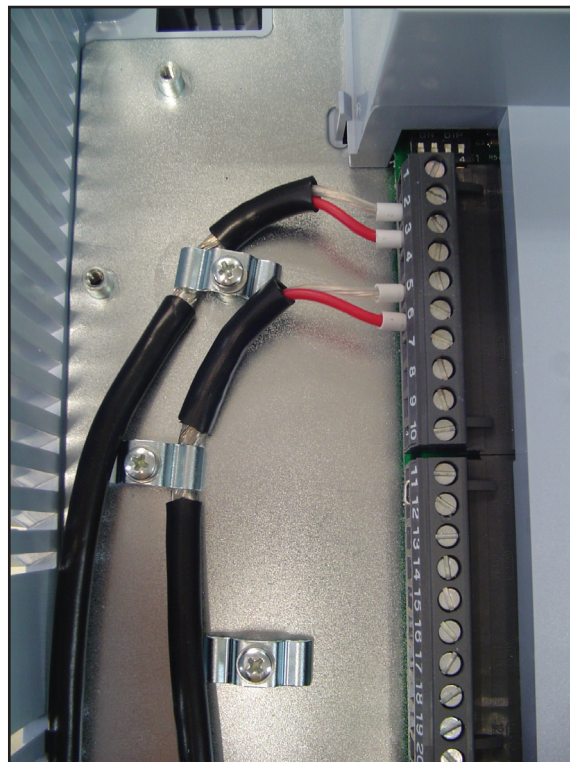

Figure 3.21 - Example of shield connection for the control wiring

5) Relays, contactors, solenoids or coils of electromechanical brakes installed close to the inverter may eventually create interferences in the control circuitry. To eliminate this effect, RC suppressors (with AC power supply) or free-wheel diodes (with DC power supply) shall be connected in parallel to the coils of these devices.



3.2.6 Typical Control Connections

Control connection #1 - Start/Stop function controlled from the keypad (Local Mode).

With this control connection it is possible to run the inverter in local mode with the factory default settings. This operation mode is recommended for first-time users, since no additional control connections are required.

For the start-up in this operation mode, please follow instructions listed in chapter 5.

Control connection #2 - 2 - Wire Start/Stop function (Remote Mode).

This wiring example is valid only for the default factory settings and if the inverter is set to remote mode. With the factory default settings, the selection of the operation mode (local/remote) is performed through the operator key  (local mode is default). Set P0220=3 to change the default setting of operator key  to remote mode.

3

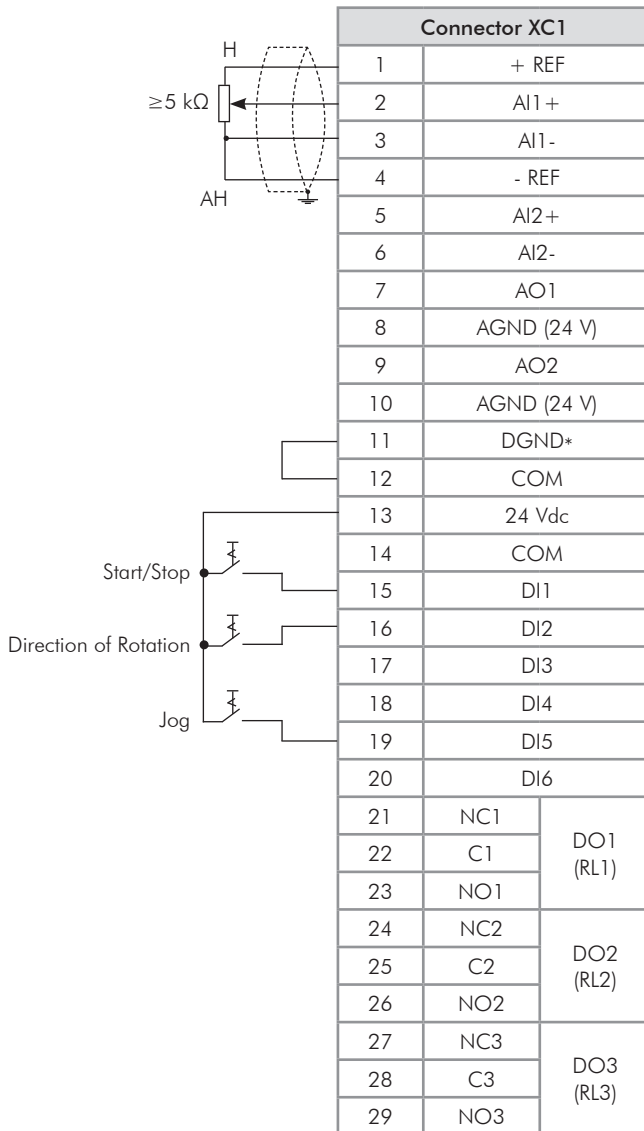

Figure 3.22 - XC1 wiring for Control Connection #2

Control connection #3 - 3 - Wire Start/Stop function.

Enabling the Start/Stop function with 3 Wire control.

Parameters to set:

Set DI3 to START

P0265=6

Set DI4 to STOP

P0266=7

Set P0224=1 (DIx) for 3 wire control in Local mode.

Set P0227=1 (DIx) for 3 wire control in Remote mode.

Set the Direction of Rotation by using digital input #2 (DI2).

Set P0223=4 to Local Mode or P0226=4 to Remote Mode.

S1 and S2 are Start (NO contact) and Stop (NC contact) push-buttons respectively.

The speed reference can be provided through the analog input (as in Control Connection #2), through the keypad (as in Control Connection #1) or through any other available source.

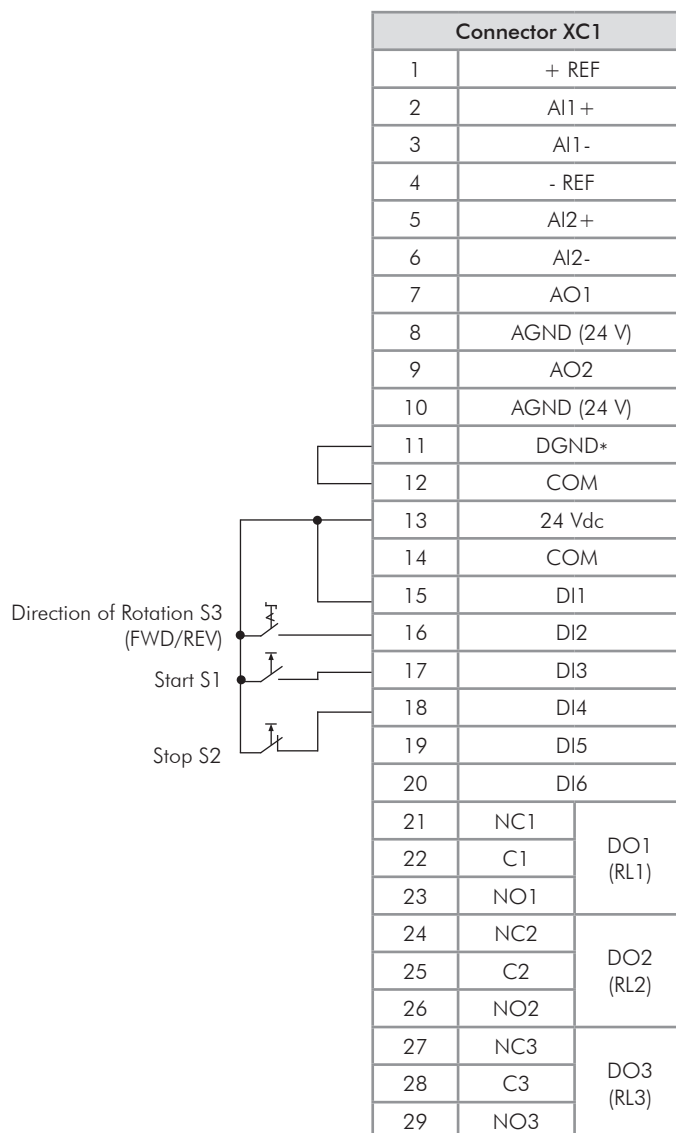

Figure 3.23 - XC1 wiring for Control Connection #3

Installation and Connection

Control connection #4 - Forward/Reverse.

Enabling the Forward/Reverse function.



Parameters to set:

Set DI3 to FORWARD

P0265=4

Set DI4 to REVERSE

P0266=5

When the Forward/Reverse function is set, it will be active either in Local or Remote mode. At the same time, the operator keys  and  will remain always inactive (even if P0224=0 or P0227=0).

The direction of rotation is determined by the forward and reverse inputs.

Clockwise to forward and counter-clockwise to reverse.

The speed reference can be provided by any source (as in Control Connection #3).

3

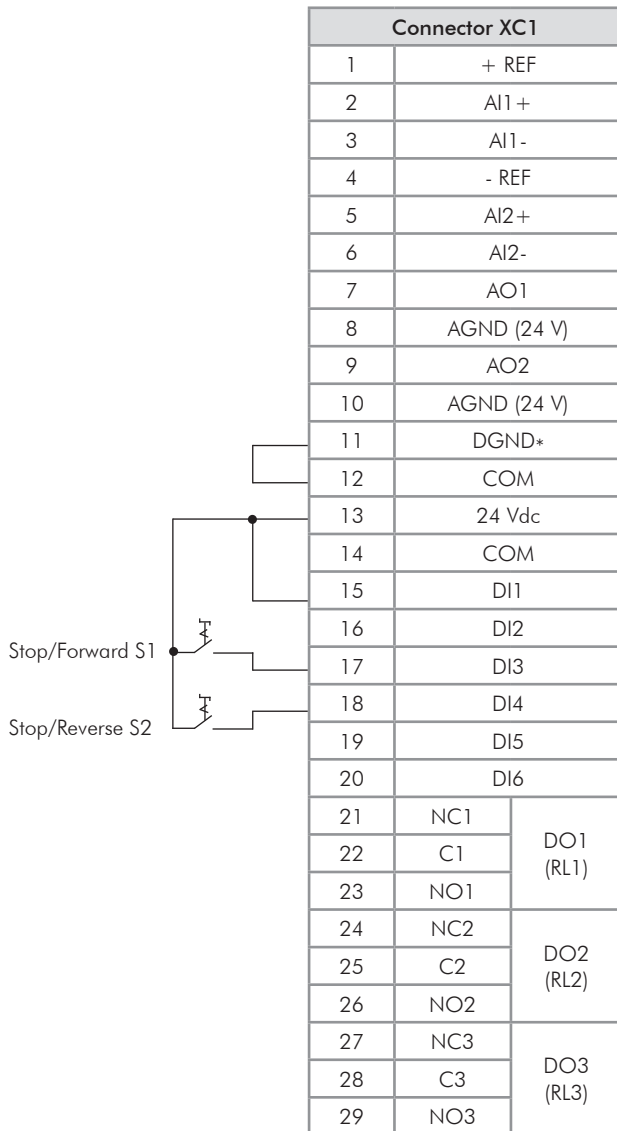

Figure 3.24 - XC1 wiring for Control Connection #4

3.3 INSTALLATION ACCORDING TO THE EUROPEAN DIRECTIVE OF ELECTROMAGNETIC COMPATIBILITY

The frame size E CFW-11 inverters have an internal RFI filter for the reduction of the electromagnetic interference. These inverters, when properly installed, meet the requirements of the electromagnetic compatibility directive – “EMC Directive 2004/108/EC”.

The CFW-11 inverter series has been designed only for industrial applications. Therefore, the emission limits of harmonic currents defined by the standards EN 61000-3-2 and EN 61000-3-2/A14 are not applicable.



ATTENTION!

Do not use inverters with internal RFI filters in IT networks (neutral is not grounded or grounding provided by a high ohm value resistor) or in grounded delta networks (“delta corner earthed”), because these type of networks damage the filter capacitors of the inverter.

3.3.1 Conformal Installation

For the conformal installation use:

1. J1 cable in the position  (XE1). Refer to item 3.2.3.1.1.
2. a) Shielded output cables (motor cables) and connect the shield at both ends (motor and inverter) with a low impedance connection for high frequency. Use the clamp supplied with the product. Make sure there is a good contact between the cable shield and the clamp. Refer to the figure 3.16 as an example. The required cable separation is presented in table 3.5. For further information, please refer to item 3.2.3. Maximum motor cable length and conducted and radiated emission levels according to the table 3.9. If a lower conducted emission level (category C2) is wished, then an external RFI filter must be used at the inverter input. For more information (RFI filter commercial reference, motor cable length and emission levels) refer to the table 3.9.
- b) As a second option only for the V/f and VVW control modes when using a sinusoidal output filter: Adjust the switching frequency in 5 or 10 kHz (P0297=2 or 3) and the parameter P0350 in 2 or 3 (not allowing the automatic reduction of the switching frequency to 2.5 kHz). Refer to tables 8.2 to 8.5 for output current specification for 5 kHz and 10 kHz. Output cables (motor cables) that are not shielded can be used, provided that RFI filters are installed at the inverter input and output, as presented in the table 3.10. The maximum motor cable length and the emission levels for each configuration are also presented. Keep the separation from the other cables according to the table 3.5. Refer to the section 3.2.3 for more information. The filters presented in table 3.10 were defined for the operation of the inverter at 5 kHz switching frequency and rated output current as shown in tables 8.2 and 8.3. Those filters can also be used for 10 kHz, however they are not optimized for it. In order to optimize them for use with the inverter at 10 kHz, refer to the tables 8.4 and 8.5.
3. Use shielded control cables, keeping them separate from the other cables as described in item 3.2.5.
4. Inverter grounding according to the instructions on item 3.2.4.

3.3.2 Standard Definitions

IEC/EN 61800-3: "Adjustable Speed Electrical Power Drives Systems"

- Environment:

First Environment: includes domestic premises. It also includes establishments directly connected without intermediate transformer to a low-voltage power supply network which supplies buildings used for domestic purposes.

Example: houses, apartments, commercial installations, or offices located in residential buildings.

Second Environment: includes all establishments other than those directly connected to a low-voltage power supply network which supplies buildings used for domestic purposes.

Example: industrial area, technical area of any building supplied by a dedicated transformer.

- Categories:

Category C1: inverters with a voltage rating less than 1000 V and intended for use in the First Environment.

Category C2: inverters with a voltage rating less than 1000 V, intended for use in the First Environment, not provided with a plug connector or a movable installations, and installed and commissioned by a professional.

Note: A professional is a person or organization familiar with the installation and/or commissioning of inverters, including the EMC aspects.

Category C3: inverters with a voltage rating less than 1000 V and intended for use in the Second Environment only (not designed for use in the First Environment).

Category C4: inverters with a voltage rating equal to or greater than 1000 V, or with a current rating equal to or greater than 400 Amps, or intended for use in complex systems in the Second Environment.

EN 55011: "Threshold values and measuring methods for radio interference from industrial, scientific and medical (ISM) high-frequency equipment"

Class B: equipment intended for use in the low-voltage power supply network (residential, commercial, and light-industrial environments).

Class A1: equipment intended for use in the low-voltage power supply network. Restricted distribution.

Note: Must be installed and commissioned by a professional when applied in the low-voltage power supply network.

Class A2: equipment intended for use in industrial environments.

3.3.3 Emission and Immunity Levels

Table 3.8 - Emission and immunity levels

EMC Phenomenon	Basic Standard	Level
Emission:		
Mains Terminal Disturbance Voltage Frequency Range: 150 kHz to 30 MHz	IEC/EN61800-3 (2004)	Refer to table 3.9.
Electromagnetic Radiation Disturbance Frequency Range: 30 MHz to 1000 MHz		
Immunity:		
Electrostatic Discharge (ESD)	IEC 61000-4-2 (1995) +A1 (1998) +A2 (2001)	4 kV for contact discharge and 8 kV for air discharge.
Fast Transient-Burst	IEC 61000-4-4 (1995) +A1 (2000) +A2 (2001)	2 kV / 5 kHz (coupling capacitor) power input cables; 1 kV / 5 kHz control cables, and remote keypad cables; 2 kV / 5 kHz (coupling capacitor) motor output cables.
Conducted Radio-Frequency Common Mode	IEC 61000-4-6 (2003)	0.15 to 80 MHz; 10 V; 80 % AM (1 kHz). Motor input cables, control cables, and remote keypad cables.
Surge Immunity	IEC 61000-4-5 (1995)	1.2/50 μ s, 8/20 μ s; 1 kV line-to-line coupling; 2 kV line-to-ground coupling.
Radio-Frequency Electromagnetic Field	IEC 61000-4-3 (2002)	80 to 1000 MHz; 10 V/m; 80 % AM (1 kHz).

Table 3.9 - Conducted and radiated emission levels and further information

Inverter model (with built-in RFI filter)	Without external RFI filter		With external RFI filter		
	Conducted emission - maximum motor cable length	Radiated emission - without metallic cabinet	External RFI filter part number - (manufacturer: EPCOS)	Conducted emission - maximum motor cable length	Radiated emission - without metallic cabinet
	Category C3	Category		Category C2	Category
CFW11 0142 T 2	100 m (330 ft)	C2	B84143B0150S020	100 m (330 ft)	C2
CFW11 0180 T 2	100 m (330 ft)	C2	B84143B0180S020 ⁽¹⁾	100 m (330 ft)	C2
CFW11 0211 T 2	100 m (330 ft)	C2	B84143B0250S020 ⁽²⁾	100 m (330 ft)	C2
CFW11 0105 T 4	100 m (330 ft)	C2	B84143B0150S020	100 m (330 ft)	C2
CFW11 0142 T 4	100 m (330 ft)	C2	B84143B0150S020	100 m (330 ft)	C2
CFW11 0180 T 4	100 m (330 ft)	C2	B84143B0180S020 ⁽¹⁾	100 m (330 ft)	C2
CFW11 0211 T 4	100 m (330 ft)	C2	B84143B0250S020 ⁽²⁾	100 m (330 ft)	C2

(1) For inverter/filter surrounding air temperature higher than 40 °C (104 °F) and continuous output current higher than 172 Arms, it's required to use B84143B0250S020 filter.

(2) For inverter/filter surrounding air temperature of 40 °C (104 °F) and HD applications (heavy duty cycle, output current < 180 Arms), it's possible to use B84143B0180S020 filter.

Installation and Connection

Table 3.10 - Required RFI filters for unshielded motor cable installations and further information on conducted and radiated levels

Inverter model (with built-in RFI filter)	Inverter duty cycle	External RFI filters part number (manufacturer: EPCOS)				Conducted emission - maximum motor cable length	Radiated emission - category	
		Surrounding air temperature = 45 °C (113 °F)		Surrounding air temperature = 40 °C (104 °F)			Category C1	Without metallic cabinet
		Inverter input	Inverter output ⁽¹⁾	Inverter input	Inverter output ⁽¹⁾			
CFW11 0142 T 2	ND	B84143-D150-R127	B84143-V180-R127	B84143-D150-R127	B84143-V180-R127	300 m (984.2 ft)	C2	C2
	HD	B84143-D120-R127	B84143-V180-R127	B84143-D120-R127	B84143-V180-R127			
CFW11 0180 T 2	ND	B84143-D200-R127	B84143-V180-R127	B84143-D200-R127	B84143-V180-R127	300 m (984.2 ft)	C2	C2
	HD	B84143-D150-R127	B84143-V180-R127	B84143-D150-R127	B84143-V180-R127			
CFW11 0211 T 2	ND	B84143-D200-R127	B84143-V320-R127	B84143-D200-R127	B84143-V320-R127	300 m (984.2 ft)	C2	C2
	HD	B84143-D200-R127	B84143-V180-R127	B84143-D200-R127	B84143-V180-R127			
CFW11 0105 T 4	ND	B84143-D90-R127	B84143-V95-R127	B84143-D90-R127	B84143-V95-R127	300 m (984.2 ft)	C2	C2
	HD	B84143-D75-R127	B84143-V95-R127	B84143-D75-R127	B84143-V95-R127			
CFW11 0142 T 4	ND	B84143-D120-R127	B84143-V180-R127	B84143-D120-R127	B84143-V180-R127	300 m (984.2 ft)	C2	C2
	HD	B84143-D90-R127	B84143-V95-R127	B84143-D120-R127	B84143-V180-R127			
CFW11 0180 T 4	ND	B84143-D150-R127	B84143-V180-R127	B84143-D150-R127	B84143-V180-R127	300 m (984.2 ft)	C2	C2
	HD	B84143-D120-R127	B84143-V180-R127	B84143-D120-R127	B84143-V180-R127			
CFW11 0211 T 4	ND	B84143-D200-R127	B84143-V180-R127	B84143-D200-R127	B84143-V320-R127	300 m (984.2 ft)	C2	C2
	HD	B84143-D150-R127	B84143-V180-R127	B84143-D150-R127	B84143-V180-R127			

(1) The output filter is of the sinusoidal type, i.e., the motor voltage waveform is approximately sinusoidal, not pulsed as in the applications without this filter.

KEYPAD AND DISPLAY

This chapter describes:

- The operator keys and their functions;
- The indications on the display;
- How parameters are organized.

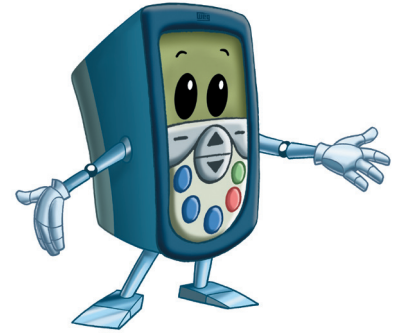

4.1 INTEGRAL KEYPAD - HMI-CFW11

The integral keypad can be used to operate and program (view / edit all parameters) of the CFW-11 inverter. The inverter keypad navigation is similar to the one used in cell phones and the parameters can be accessed in numerical order or through groups (Menu).

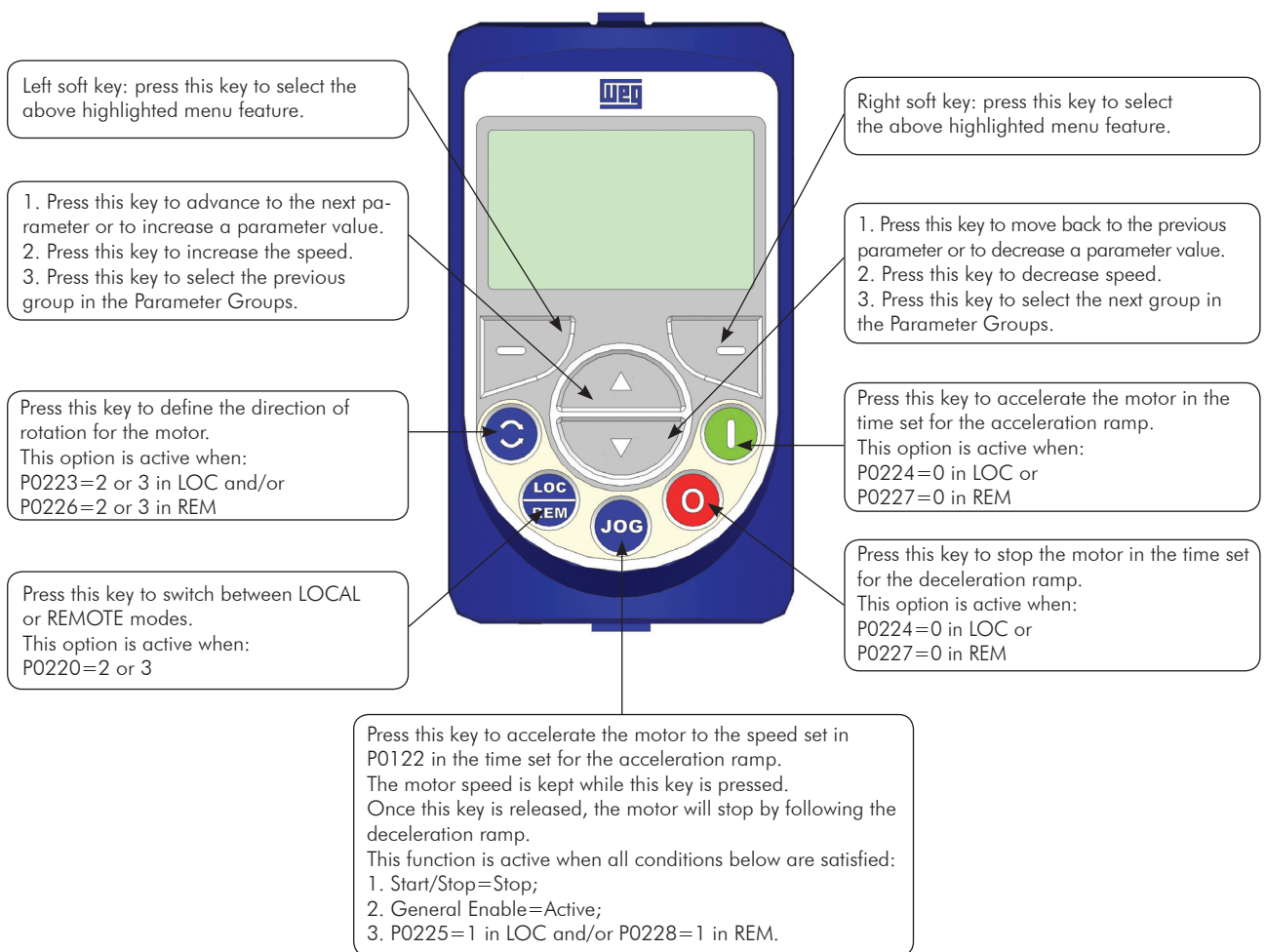

Battery:

Figure 4.1 - Operator keys



NOTE!

The battery is necessary only to keep the internal clock operation when the inverter stays without power. If the battery is completely discharged or if it is not installed in the keypad, the displayed clock time will be invalid and an alarm condition 'A181 - Invalid clock time' will be indicated whenever the AC power is applied to the inverter.

The battery life expectancy is of approximately 10 years. When necessary, replace the battery by another of the CR2032 type.



1 Cover for battery access



2 Press the cover and rotate it counterclockwise



3 Remove the cover



4 Remove the battery with the help of a screwdriver positioned in the right side



5 HMI without the battery

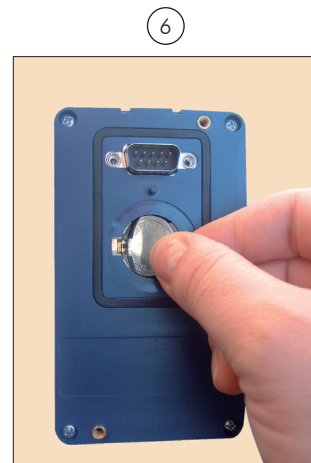

6 Install the new battery positioning it first at the left side

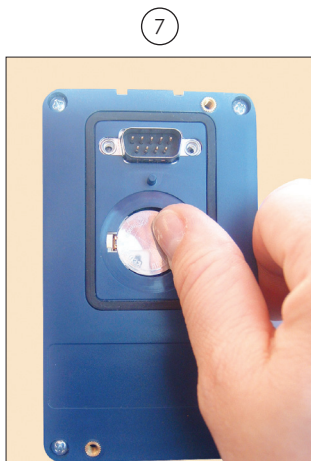

7 Press the battery for its insertion



8 Put the cover back and rotate it clockwise

Figure 4.2 - HMI battery replacement



NOTE!

At the end of the battery useful life, please do not discard batteries in your waste container, but use a battery disposal site.

Installation:

- ☑ The keypad can be installed or removed from the inverter with or without AC power applied to the inverter.
- ☑ The HMI supplied with the product can also be used for remote command of the inverter. In this case, use a cable with male and female D-Sub9 (DB-9) connectors wired pin to pin (mouse extension type) or a market standard Null-Modem cable. Maximum length of 10 m (33 ft). It is recommended the use of the M3 x 5.8 standoffs supplied with the product. Recommended torque: 0.5 N.m (4.5 lbf.in).

When power is applied to the inverter, the display automatically enters the monitoring mode. Figure 4.3 (a) presents the monitoring screen displayed for the factory default settings. By properly setting specific inverter parameters, other variables can be displayed in the monitoring mode or the value of a parameter can be displayed using bar graphs or with larger characters as presented in figures 4.3 (b) and (c).

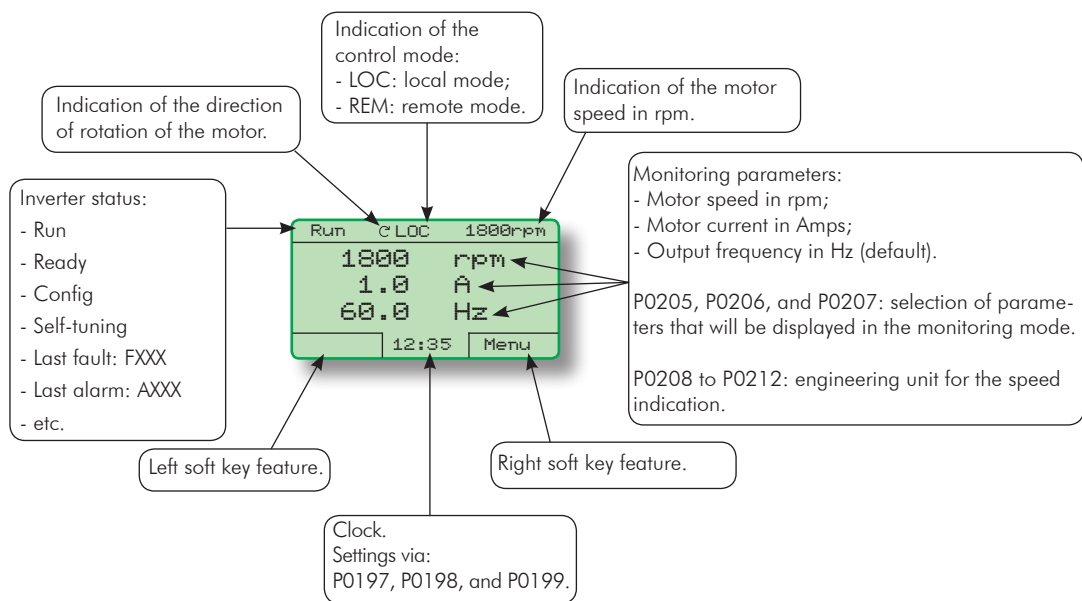

(a) Monitoring screen with the factory default settings

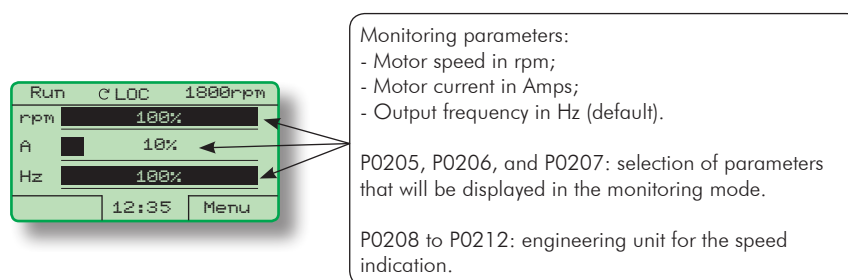

(b) Example of a monitoring screen with bar graphs

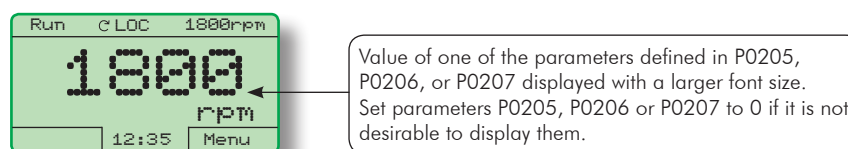

(c) Example of a monitoring screen displaying a parameter with a larger font size

Figure 4.3 (a) to (c) - Keypad monitoring modes

4.2 PARAMETERS ORGANIZATION

When the right soft key ("MENU") is pressed in the monitoring mode, the display shows the first 4 groups of parameters. An example of how the groups of parameters are organized is presented in table 4.1. The number and name of the groups may change depending on the firmware version used. For further details on the existent groups for the firmware version used, please refer to the Software Manual.

Table 4.1 - Groups of parameters

Level 0	Level 1		Level 2		Level 3			
Monitoring	00	ALL PARAMETERS						
	01	PARAMETER GROUPS	20	Ramps				
			21	Speed References				
			22	Speed Limits				
			23	V/f Control				
			24	Adjust. V/f Curve				
			25	VVW Control				
			26	V/f Current Limit.				
			27	V/f DC Volt.Limit.				
			28	Dynamic Braking				
			29	Vector Control			90	Speed Regulator
							91	Current Regulator
							92	Flux Regulator
							93	I/F Control
							94	Self-Tuning
							95	Torque Curr.Limit.
							96	DC Link Regulator
					30	HMI		
					31	Local Command		
					32	Remote Command		
					33	3-Wire Command		
					34	FWD/REV Run Comm.		
					35	Zero Speed Logic		
					36	Multispeed		
					37	Electr. Potentiom.		
					38	Analog Inputs		
					39	Analog Outputs		
					40	Digital Inputs		
					41	Digital Outputs		
					42	Inverter Data		
			43	Motor Data				
			44	FlyStart/RideThru				
		45	Protections					
		46	PID Regulator					
		47	DC Braking					
		48	Skip Speed					
		49	Communication					
				110	Local/Rem Config.			
				111	Status/Commands			
				112	CANopen/DeviceNet			
				113	Serial RS232/485			
				114	Anybus			
				115	Profibus DP			
		50	SoftPLC					
		51	PLC					
		52	Trace Function					
	02	ORIENTED START-UP						
	03	CHANGED PARAMETERS						
	04	BASIC APPLICATION						
	05	SELF-TUNING						
	06	BACKUP PARAMETERS						
	07	I/O CONFIGURATION	38	Analog Inputs				
			39	Analog Outputs				
			40	Digital Inputs				
			41	Digital Outputs				
	08	FAULT HISTORY						
	09	READ ONLY PARAMS.						

FIRST TIME POWER-UP AND START-UP

This chapter describes how to:

- Check and prepare the inverter before power-up.
- Power-up the inverter and check the result.
- Set the inverter for the operation in the V/f mode based on the power supply and motor information by using the Oriented Start-Up routine and the Basic Application group.

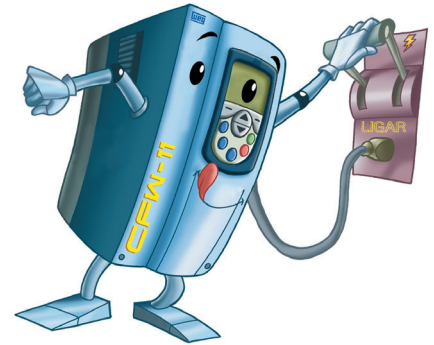

NOTE!

For a detailed description of the VVW or Vector control modes and for other available functions, please refer to the CFW-11 Software Manual.

5.1 PREPARE FOR START-UP

The inverter shall have been already installed according to the recommendations listed in Chapter 3 – Installation and Connection. The following recommendations are applicable even if the application design is different from the suggested control connections.



DANGER!

Always disconnect the main power supply before performing any inverter connection.

- 1) Check if power, grounding, and control connections are correct and firmly secured.
- 2) Remove from the inside of the inverter all installation material left behind.
- 3) Verify the motor connections and if the motor voltage and current is within the rated value of the inverter.
- 4) Mechanically uncouple the motor from the load:
If the motor cannot be uncoupled, make sure that the chosen direction of rotation (forward or reverse) will not result in personnel injury and/or equipment damage.
- 5) Return the inverter covers.
- 6) Measure the power supply voltage and verify if it is within the range listed in chapter 8.
- 7) Apply power to the input:
Close the input disconnect switch.
- 8) Check the result of the first time power-up:
The keypad should display the standar monitoring mode (figure 4.3 (a)) and the status LED should be steady green.

5.2 START-UP

The start-up procedure for the V/f is described in three simple steps by using the **Oriented Start-up routine** and the **Basic Application group**.

Steps:

- (1) Set the password for parameter modification.
- (2) Execute the **Oriented Start-up routine**.
- (3) Set the parameters of the **Basic Application group**.

5.2.1 Password Setting in P0000

Step	Action/Result	Display indication
1	- Monitoring Mode. - Press "Menu" (right soft key).	
2	- Group "00 ALL PARAMETERS" is already selected. - Press "Select".	
3	- Parameter "Access to Parameters P0000: 0" is already selected. - Press "Select".	
4	- To set the password, press the Up Arrow until number 5 is displayed in the keypad.	
5	- When number 5 is displayed in the keypad, press "Save".	
6	- If the setting has been properly performed, the keypad should display "Access to Parameters P0000: 5". - Press "Return" (left soft key).	
7	- Press "Return".	
8	- The display returns to the Monitoring Mode.	

Figure 5.1 - Steps for allowing parameters modification via P0000

5.2.2 Oriented Start-Up

There is a group of parameters named "Oriented Start-up" that makes the inverter settings easier. Inside this group, there is a parameter – P0317 – that shall be set to enter into the Oriented Start-up routine.

The Oriented Start-up routine allows you to quickly set up the inverter for operation with the line and motor used. This routine prompts you for the most commonly used parameters in a logic sequence.

In order to enter into the Oriented Start-up routine, follow the steps presented in figure 5.2, first modifying parameter P0317 to 1 and then, setting all remaining parameters as they are prompted in the display.

The use of the Oriented Start-up routine for setting the inverter parameters may lead to the automatic modification of other internal parameters and/or variables of the inverter.

During the Oriented Start-up routine, the message "Config" will be displayed at the left top corner of the keypad.

Step	Action/Result	Display indication
1	- Monitoring Mode. - Press "Menu" (right soft key).	
2	- Group "00 ALL PARAMETERS" has been already selected. 	
3	- Group "01 PARAMETER GROUPS" is selected. 	
4	- Group "02 ORIENTED START-UP" is then selected. - Press "Select".	
5	- Parameter "Oriented Start-Up P0317: No" has been already selected. - Press "Select".	
6	- The value of "P0317 = [000] No" is displayed. 	
7	- The parameter value is modified to "P0317 = [001] Yes". - Press "Save".	
8	- At this point the Oriented Start-up routine starts and the "Config" status is displayed at the top left corner of the keypad. - The parameter "Language P0201: English" is already selected. - If needed, change the language by pressing "Select". Then, press or to scroll through the available options and press "Save" to select a different language. 	
9	- If needed, change the value of P0202 according to the type of control. To do so, press "Select". - The settings listed here are valid only for P0202=0 (V/f 60 Hz) or P0202=1 (V/f 50 Hz). For other options (Adjustable V/f, VVW, or Vector modes), please refer to the Software Manual. 	

Figure 5.2 - Oriented Start-up

First Time Power-Up and Start-Up











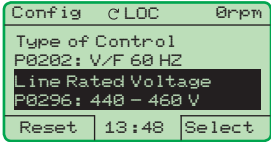

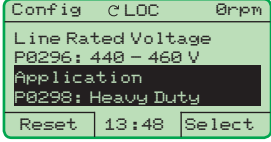

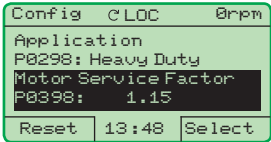
Step	Action/Result	Display indication
10	<p>- If needed, change the value of P0296 according to the line rated voltage. To do so, press "Select". This modification will affect P0151, P0153, P0185, P0321, P0322, P0323, and P0400.</p> 	
11	<p>- If needed, change the value of P0298 according to the inverter application. To do so, press "Select". This modification will affect P0156, P0157, P0158, P0401, P0404 and P0410 (this last one only if P0202 = 0, 1, or 2 – V/f control). The time and the activation level of the overload protection will be affected as well.</p> 	
12	<p>- If needed, change the value of P0398 according to the motor service factor. To do so, press "Select". This modification will affect the current value and the activation time of the motor overload function.</p> 	
13	<p>- If needed, change the value of P0400 according to the motor rated voltage. To do so, press "Select". This modification adjusts the output voltage by a factor $x = P0400/P0296$.</p> 	
14	<p>- If needed, change the value of P0401 according to the motor rated current. To do so, press "Select". This modification will affect P0156, P0157, P0158, and P0410.</p> 	
15	<p>- If needed, set P0402 according to the motor rated speed. To do so, press "Select". This modification affects P0122 to P0131, P0133, P0134, P0135, P0182, P0208, P0288, and P0289.</p> 	
16	<p>- If needed, set P0403 according to the motor rated frequency. To do so, press "Select". This modification affects P0402.</p> 	
17	<p>- If needed, change the value of P0404 according to the motor rated power. To do so, press "Select". This modification affects P0410.</p> 	
18	<p>- This parameter will only be visible if the encoder board ENC1 is installed in the inverter. - If there is an encoder connected to the motor, set P0405 according to the encoder pulses number. To do so, press "Select".</p> 	
19	<p>- If needed, set P0406 according to the motor ventilation. To do so, press "Select". - To complete the Oriented Start-Up routine, press "Reset" (left soft key) or .</p>	
20	<p>- After few seconds, the display returns to the Monitoring Mode.</p>	

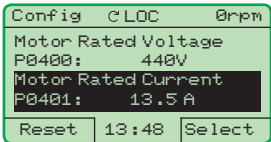
Figure 5.2 (cont.) - Oriented Start-up

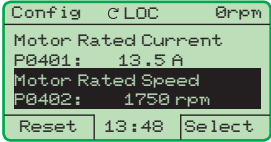
5.2.3 Setting Basic Application Parameters

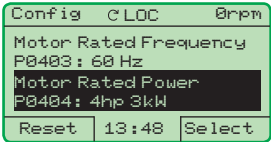
After running the Oriented Start-up routine and properly setting the parameters, the inverter is ready to operate in the V/f mode.

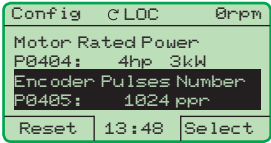
The inverter has a number of other parameters that allow its adaptation to the most different applications. This manual presents some basic parameters that shall be set in most cases. There is a group named “Basic Application” to make this task easier. A summary of the parameters inside this group is listed in table 5.1. There is also a group of read only parameters that shows the value of the most important inverter variables such as voltage, current, etc. The main parameters comprised in this group are listed in table 5.2. For further details, please refer to the CFW-11 Software Manual.

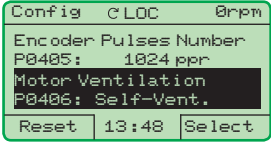
Follow steps outlined in figure 5.3 to set the parameters of the Basic Application group.

The procedure for start-up in the V/f operation mode is finished after setting these parameters.

Step	Action/Result	Display indication
1	- Monitoring Mode. - Press “Menu” (right soft key).	
2	- Group “00 ALL PARAMETERS” has been already selected.	
3	- Group “01 PARAMETER GROUPS” is then selected.	
4	- Group “02 ORIENTED START-UP” is then selected.	
5	- Group “03 CHANGED PARAMETERS” is selected.	
6	- Group “04 BASIC APPLICATION” is selected. - Press “Select”.	
7	- Parameter “Acceleration Time P0100: 20.0 s” has been already selected. - If needed, set P0100 according to the desired acceleration time. To do so, press “Select”. - Proceed similarly until all parameters of group “04 BASIC APPLICATION” have been set. When finished, press “Return” (left soft key).	
8	- Press “Return”.	
9	- The display returns to the Monitoring Mode and the inverter is ready to run.	

Figure 5.3 - Setting parameters of the Basic Application group

Table 5.1 - Parameters comprised in the Basic Application group

Parameter	Name	Description	Setting Range	Factory Setting	User Setting
P0100	Acceleration Time	- Defines the time to linearly accelerate from 0 up to the maximum speed (P0134). - If set to 0.0 s, it means no acceleration ramp.	0.0 to 999.0 s	20.0 s	
P0101	Deceleration Time	- Defines the time to linearly decelerate from the maximum speed (P0134) up to 0. - If set to 0.0 s, it means no deceleration ramp.	0.0 to 999.0 s	20.0 s	
P0133	Minimum Speed	- Defines the minimum and maximum values of the speed reference when the drive is enabled. - These values are valid for any reference source.	0 to 18000 rpm	90 rpm (60 Hz motor) 75 rpm (50 Hz motor)	
P0134	Maximum Speed			1800 rpm (60 Hz motor) 1500 rpm (50 Hz motor)	
P0135	Max. Output Current (V/F control mode current limitation)	- Avoids motor stall under torque overload condition during the acceleration or deceleration. - The factory default setting is for "Ramp Hold": if the motor current exceeds the value set at P0135 during the acceleration or deceleration, the motor speed will not be increased (acceleration) or decreased (deceleration) anymore. When the motor current reaches a value below the programmed in P0135, the motor speed is again increased or decreased. - Other options for the current limitation are available. Refer to the CFW-11 Software Manual.	$0.2 \times I_{rat-HD}$ to $2 \times I_{rat-HD}$	$1.5 \times I_{rat-HD}$	
					
P0136	Manual Torque Boost	- Operates in low speeds, modifying the output voltage x frequency curve to keep the torque constant. - Compensates the voltage drop at the motor stator resistance. This function operates in low speeds increasing the inverter output voltage to keep the torque constant in the V/f mode. - The optimal setting is the smallest value of P0136 that allows the motor to start satisfactorily. An excessive value will considerably increase the motor current in low speeds, and may result in a fault (F048, F051, F071, F072, F078 or F183) or alarm (A046, A047, A050 or A110) condition.	0 to 9	1	
					

Table 5.2 - Main read only parameters

Parameter	Description	Setting Range
P0001	Speed Reference	0 to 18000 rpm
P0002	Motor Speed	0 to 18000 rpm
P0003	Motor Current	0.0 to 4500.0 A
P0004	DC Link Voltage (Ud)	0 to 2000 V
P0005	Motor Frequency	0.0 to 300.0 Hz
P0006	VFD Status	0 = Ready 1 = Run 2 = Undervoltage 3 = Fault 4 = Self-tuning 5 = Configuration 6 = DC-Braking 7 = STO
P0007	Motor Voltage	0 to 2000 V
P0009	Motor Torque	-1000.0 to 1000.0 %
P0010	Output Power	0.0 to 6553.5 kW
P0012	DI8 to DI1 Status	0000h to 00FFh
P0013	DO5 to DO1 Status	0000h to 001Fh
P0018	AI1 Value	-100.00 to 100.00 %
P0019	AI2 Value	-100.00 to 100.00 %
P0020	AI3 Value	-100.00 to 100.00 %
P0021	AI4 Value	-100.00 to 100.00 %
P0023	Software Version	0.00 to 655.35
P0027	Accessories Config. 1	Hexadecimal code representing the identified accessories. Refer to chapter 7.
P0028	Accessories Config. 2	
P0029	Power Hardware Config.	Hexadecimal code according to the available models and option kits. Refer to the software manual for a complete code list.
P0030	IGBTs Temperature U	-20.0 to 150.0 °C (-4 °F to 302 °F)
P0031	IGBTs Temperature V	-20.0 to 150.0 °C (-4 °F to 302 °F)
P0032	IGBTs Temperature W	-20.0 to 150.0 °C (-4 °F to 302 °F)
P0033	Rectifier Temperature	-20.0 to 150.0 °C (-4 °F to 302 °F)
P0034	Internal Air Temp.	-20.0 to 150.0 °C (-4 °F to 302 °F)
P0036	Fan Heatsink Speed	0 to 15000 rpm
P0037	Motor Overload Status	0 to 100 %
P0038	Encoder Speed	0 to 65535 rpm
P0040	PID Process Variable	0.0 to 100.0 %
P0041	PID Setpoint Value	0.0 to 100.0 %
P0042	Time Powered	0 to 65535h
P0043	Time Enabled	0.0 to 6553.5h
P0044	kWh Output Energy	0 to 65535 kWh
P0045	Fan Enabled Time	0 to 65535h
P0048	Present Alarm	0 to 999
P0049	Present Fault	0 to 999

Parameter	Description	Setting Range
P0050	Last Fault	0 to 999
P0051	Last Fault Day/Month	00/00 to 31/12
P0052	Last Fault Year	00 to 99
P0053	Last Fault Time	00:00 to 23:59
P0054	Second Fault	0 to 999
P0055	Second Flt. Day/Month	00/00 to 31/12
P0056	Second Fault Year	00 to 99
P0057	Second Fault Time	00:00 to 23:59
P0058	Third Fault	0 to 999
P0059	Third Fault Day/Month	00/00 to 31/12
P0060	Third Fault Year	00 to 99
P0061	Third Fault Time	00:00 to 23:59
P0062	Fourth Fault	0 to 999
P0063	Fourth Flt. Day/Month	00/00 to 31/12
P0064	Fourth Fault Year	00 to 99
P0065	Fourth Fault Time	00:00 to 23:59
P0066	Fifth Fault	0 to 999
P0067	Fifth Fault Day/Month	00/00 to 31/12
P0068	Fifth Fault Year	00 to 99
P0069	Fifth Fault Time	00:00 to 23:59
P0070	Sixth Fault	0 to 999
P0071	Sixth Fault Day/Month	00/00 to 31/12
P0072	Sixth Fault Year	00 to 99
P0073	Sixth Fault Time	00:00 to 23:59
P0074	Seventh Fault	0 to 999
P0075	Seventh Flt.Day/Month	00/00 to 31/12
P0076	Seventh Fault Year	00 to 99
P0077	Seventh Fault Time	00:00 to 23:59
P0078	Eighth Fault	0 to 999
P0079	Eighth Flt. Day/Month	00/00 to 31/12
P0080	Eighth Fault Year	00 to 99
P0081	Eighth Fault Time	00:00 to 23:59
P0082	Ninth Fault	0 to 999
P0083	Ninth Fault Day/Month	00/00 to 31/12
P0084	Ninth Fault Year	00 to 99
P0085	Ninth Fault Time	00:00 to 23:59
P0086	Tenth Fault	0 to 999
P0087	Tenth Fault Day/Month	00/00 to 31/12
P0088	Tenth Fault Year	00 to 99
P0089	Tenth Fault Time	00:00 to 23:59
P0090	Current At Last Fault	0.0 to 4000.0 A
P0091	DC Link At Last Fault	0 to 2000 V
P0092	Speed At Last Fault	0 to 18000 rpm
P0093	Reference Last Fault	0 to 18000 rpm
P0094	Frequency Last Fault	0.0 to 300.0 Hz
P0095	Motor Volt.Last Fault	0 to 2000 V
P0096	DIx Status Last Fault	0000h to 00FFh
P0097	DOx Status Last Fault	0000h to 001Fh

5.3 SETTING DATE AND TIME

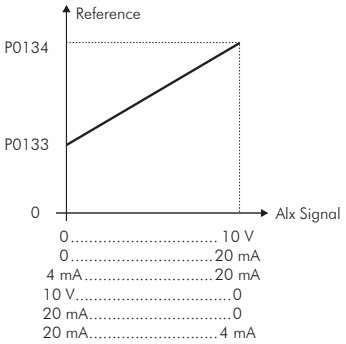
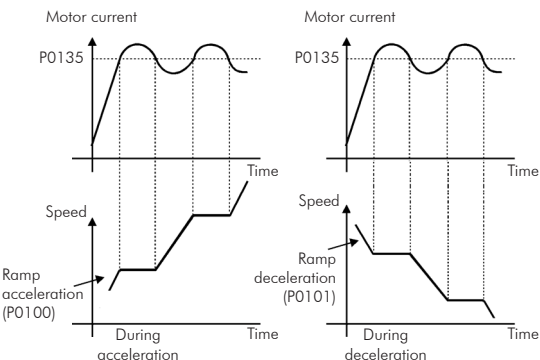
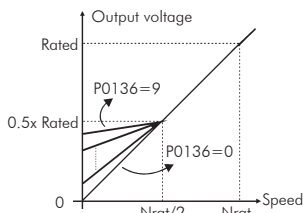
Step	Action/Result	Display indication
1	Monitoring Mode. - Press "Menu" (right soft key).	
2	- Group "00 ALL PARAMETERS" is already selected. 	
3	- Group "01 PARAMETER GROUPS" is selected. - Press "Select"	
4	- A new list of groups is displayed and group "20 Ramps" is selected. - Press until you reach group "30 HMI".	
5	- Group "30 HMI" is selected. - Press "Select".	

Step	Action/Result	Display indication
6	- Parameter "Day P0194" is already selected. - If needed, set P0194 according to the actual day. To do so, press "Select" and then, or to change P0194 value. - Follow the same steps to set parameters "Month P0195" to "Seconds P0199".	
7	- Once the setting of P0199 is over, the Real Time Clock is now updated. - Press "Return"	
8	- Press "Return".	
9	- Press "Return".	
10	- The display is back to the Monitoring Mode.	

Figure 5.4 - Setting date and time

5.4 BLOCKING PARAMETERS MODIFICATION

To prevent unauthorized or unintended parameters modification, parameter P0000 should be set to a value different from 5. Follow the same procedures described in item 5.2.1.

5.5 HOW TO CONNECT A PC



NOTES!

- Always use a standard host/device shielded USB cable. Unshielded cables may lead to communication errors.
- Recommended cables: Samtec:
USBC-AM-MB-B-B-S-1 (1 meter);
USBC-AM-MB-B-B-S-2 (2 meters);
USBC-AM-MB-B-B-S-3 (3 meters).
- The USB connection is galvanically isolated from the mains power supply and from other high voltages internal to the inverter. However, the USB connection is not isolated from the Protective Ground (PE). Use an isolated notebook for the USB connection or a desktop connected to the same Protective Ground (PE) of the inverter.

Install the SuperDrive G2 software to control motor speed, view, or edit inverter parameters through a personal computer (PC).

Basic procedures for transferring data from the PC to the inverter:

1. Install the SuperDrive G2 software in the PC;
2. Connect the PC to the inverter through a USB cable;
3. Start SuperDrive G2;
4. Choose "Open" and the files stored in the PC will be displayed;
5. Select the file;
6. Use the command "Write Parameters to the Drive".

All parameters are now transferred to the inverter.

For further information on SuperDrive G2 software, please refer SuperDrive Manual.

5.6 FLASH MEMORY MODULE

Location as presented in figure 2.2 item D.

Features:

- Store a copy of the inverter parameters;
- Transfer parameters stored in the FLASH memory to the inverter;
- Transfer firmware stored in the FLASH memory to the inverter;
- Store programs created by the SoftPLC.

Whenever the inverter is powered up, this program is transferred to the RAM memory located in the inverter control board and executed.

Refer to the CFW-11 Software Manual and to SoftPLC Manual for further details.



ATTENTION!

Before installing or removing the FLASH memory module, disconnect the inverter power supply and wait for the complete discharge of the capacitors.

TROUBLESHOOTING AND MAINTENANCE

This chapter:

- Lists all faults and alarms that may occur.
- Indicates the possible causes of each fault and alarm.
- Lists most frequent problems and corrective actions.
- Presents instructions for periodic inspections and preventive maintenance in the equipment.

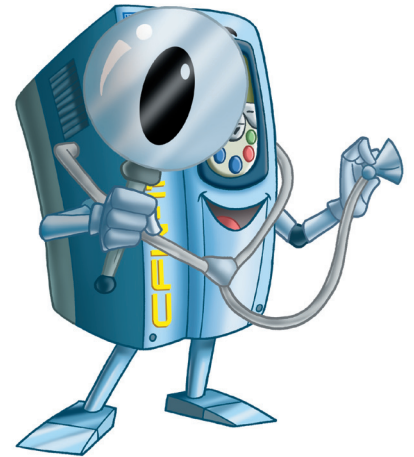

6.1 OPERATION OF THE FAULTS AND ALARMS

When a fault is detected (fault (FXXX)):

- ☑ The PWM pulses are blocked;
- ☑ The keypad displays the fault code and description;
- ☑ The "STATUS" LED starts flashing red;
- ☑ The output relay set to "NO FAULT" opens;
- ☑ Some control circuitry data is saved in the EEPROM memory:
 - Keypad and EP (Electronic Pot) speed references, in case the function "Reference backup" is enabled in P0120;
 - The fault code that occurred (shifts the last nine previous faults and alarms);
 - The state of the motor overload function integrator;
 - The state of the operating hours counter (P0043) and the powered-up hours counter (P0042).

Reset the inverter to return the drive to a "READY" condition in the event of a fault. The following reset options are available:

- ☑ Removing the power supply and reapplying it (power-on reset);
- ☑ Pressing the operator key  (manual reset);
- ☑ Through the "Reset" soft key;
- ☑ Automatically by setting P0206 (auto-reset);
- ☑ Through a digital input: DIx=20 (P0263 to P0270).

When an alarm situation (alarm (AXXX)) is detected:

- ☑ The keypad displays the alarm code and description;
- ☑ The "STATUS" LED changes to yellow;
- ☑ The PWM pulses are not blocked (the inverter is still operating).

6.2 FAULTS, ALARMS AND POSSIBLE CAUSES

Table 6.1 - Faults, alarms and possible causes

Fault/Alarm	Description	Possible Causes
F006: Imbalance or Input Phase Loss	Mains voltage imbalance too high or phase missing in the input power supply. Note: - If the motor is unloaded or operating with reduced load this fault may not occur. - Fault delay is set at parameter P0357. P0357=0 disables the fault.	<input checked="" type="checkbox"/> Phase missing at the inverter's input power supply. <input checked="" type="checkbox"/> Input voltage imbalance >5 %.
F021: DC Bus Undervoltage	DC bus undervoltage condition occurred.	<input checked="" type="checkbox"/> The input voltage is too low and the DC bus voltage dropped below the minimum permitted value (monitor the value at Parameter P0004): Ud < 223 V - For a 220-230 V three-phase input voltage; Ud < 385 V - For a 380 V input voltage (P0296=1); Ud < 405 V - For a 400-415 V input voltage (P0296=2); Ud < 446 V - For a 440-460 V input voltage (P0296=3); Ud < 487 V - For a 480 V input voltage (P0296=4). <input checked="" type="checkbox"/> Phase loss in the input power supply. <input checked="" type="checkbox"/> Pre-charge circuit failure. <input checked="" type="checkbox"/> Parameter P0296 was set to a value above of the power supply rated voltage.
F022: DC Bus Overvoltage	DC bus overvoltage condition occurred.	<input checked="" type="checkbox"/> The input voltage is too high and the DC bus voltage surpassed the maximum permitted value: Ud > 400 V - For 220-230 V input models (P0296=0); Ud > 800 V - For 380-480 V input models (P0296=1, 2, 3, or 4). <input checked="" type="checkbox"/> Inertia of the driven-load is too high or deceleration time is too short. <input checked="" type="checkbox"/> Wrong settings for parameters P0151, or P0153, or P0185.
F030: Power Module U Fault	Desaturation of IGBT occurred in Power Module U.	<input checked="" type="checkbox"/> Short-circuit between motor phases U and V or U and W.
F034: Power Module V Fault	Desaturation of IGBT occurred in Power Module V.	<input checked="" type="checkbox"/> Short-circuit between motor phases V and U or V and W.
F038: Power Module W Fault	Desaturation of IGBT occurred in Power Module W.	<input checked="" type="checkbox"/> Short-circuit between motor phases W and U or W and V.
F042: DB IGBT Fault	Desaturation of Dynamic Braking IGBT occurred.	<input checked="" type="checkbox"/> Short-circuit between the connection cables of the dynamic braking resistor.
A046: High Load on Motor	Load is too high for the used motor. Note: It may be disabled by setting P0348=0 or 2.	<input checked="" type="checkbox"/> Settings of P0156, P0157, and P0158 are too low for the used motor. <input checked="" type="checkbox"/> Motor shaft load is excessive.
A047: IGBT Overload Alarm	An IGBT overload alarm occurred. Note: It may be disabled by setting P0350=0 or 2.	<input checked="" type="checkbox"/> High current at the inverter output – consider the values of the tables 8.1 to 8.5 according to the used switching frequency.
F048: IGBT Overload Fault	An IGBT overload fault occurred.	<input checked="" type="checkbox"/> High current at the inverter output – consider the values of the tables 8.1 to 8.5 according to the used switching frequency.
A050: IGBT High Temperature	A high temperature alarm was detected by the NTC temperature sensors located on the IGBTs. Note: It may be disabled by setting P0353=2 or 3.	<input checked="" type="checkbox"/> Surrounding air temperature is too high (>45 °C (113 °F)) and output current is too high. <input checked="" type="checkbox"/> Heatsink fan blocked or defective. <input checked="" type="checkbox"/> Inverter heatsink is completely covered with dust.
F051: IGBT Overtemperature	IGBT overtemperature fault [measured with the temperature sensors (NTC)].	
F067: Incorrect Encoder/ Motor Wiring	Fault related to the phase relation of the encoder signals. Note: - This fault can only happen during the self-tuning routine. - It is not possible to reset this fault. - In this case, turn off the power supply, solve the problem, and then turn it on again.	<input checked="" type="checkbox"/> Output motor cables U, V, W are inverted. <input checked="" type="checkbox"/> Encoder channels A and B are inverted. <input checked="" type="checkbox"/> Encoder was not properly mounted.

Table 6.1 (cont.) - Faults, alarms and possible causes

Fault/Alarm	Description	Possible Causes
F071: Output Overcurrent	The inverter output current was too high for too long.	<input checked="" type="checkbox"/> Excessive load inertia or acceleration time too short. <input checked="" type="checkbox"/> Settings of P0135, P0169, P0170, P0171, and P0172 are too high.
F072: Motor Overload	The motor overload protection operated. Note: It may be disabled by setting P0348=0 or 3.	<input checked="" type="checkbox"/> Settings of P0156, P0157, and P0158 are too low for the used motor. <input checked="" type="checkbox"/> Motor shaft load is excessive.
F074: Ground Fault	A ground fault occurred either in the cable between the inverter and the motor or in the motor itself. Note: It may be disabled by setting P0343=0.	<input checked="" type="checkbox"/> Shorted wiring in one or more of the output phases. <input checked="" type="checkbox"/> Motor cable capacitance is too large, resulting in current peaks at the output. ⁽¹⁾
F076: Motor Current Imbalance	Fault of motor current imbalance. Note: It may be disabled by setting P0342=0.	<input checked="" type="checkbox"/> Loose connection or broken wiring between the motor and inverter connection. <input checked="" type="checkbox"/> Vector control with wrong orientation. <input checked="" type="checkbox"/> Vector control with encoder, encoder wiring or encoder motor connection inverted.
F077: DB Resistor Overload	The dynamic braking resistor overload protection operated.	<input checked="" type="checkbox"/> Excessive load inertia or deceleration time too short. <input checked="" type="checkbox"/> Motor shaft load is excessive. <input checked="" type="checkbox"/> Wrong settings for parameters P0154 and P0155.
F078: Motor Overtemperature	Fault related to the PTC temperature sensor installed in the motor. Note: - It may be disabled by setting P0351=0 or 3. - It is required to set the analog input / output to the PTC function.	<input checked="" type="checkbox"/> Excessive load at the motor shaft. <input checked="" type="checkbox"/> Excessive duty cycle (too many starts / stops per minute). <input checked="" type="checkbox"/> Surrounding air temperature too high. <input checked="" type="checkbox"/> Loose connection or short-circuit (resistance < 100 Ω) in the wiring connected to the motor thermistor. <input checked="" type="checkbox"/> Motor thermistor is not installed. <input checked="" type="checkbox"/> Blocked motor shaft.
F079: Encoder Signal Fault	Lack of encoder signals.	<input checked="" type="checkbox"/> Broken wiring between motor encoder and option kit for encoder interface. <input checked="" type="checkbox"/> Defective encoder.
F080: CPU Watchdog	Microcontroller watchdog fault.	<input checked="" type="checkbox"/> Electrical noise.
F082: Copy Function Fault	Fault while copying parameters.	<input checked="" type="checkbox"/> An attempt to copy the keypad parameters to an inverter with a different firmware version.
F084: Auto-diagnosis Fault	Auto-diagnosis fault.	<input checked="" type="checkbox"/> Please contact WEG.
A088: Keypad Comm. Fault	Indicates a problem between the keypad and control board communication.	<input checked="" type="checkbox"/> Loose keypad cable connection. <input checked="" type="checkbox"/> Electrical noise in the installation.
A090: External Alarm	External alarm via digital input. Note: It is required to set a digital input to "No external alarm".	<input checked="" type="checkbox"/> Wiring was not connected to the digital input (DI1 to DI8) set to "No external alarm".
F091: External Fault	External fault via digital input. Note: It is required to set a digital input to "No external fault".	<input checked="" type="checkbox"/> Wiring was not connected to the digital input (DI1 to DI8) set to "No external fault".
F099: Invalid Current Offset	Current measurement circuit is measuring a wrong value for null current.	<input checked="" type="checkbox"/> Defect in the inverter internal circuitry.
A110: High Motor Temperature	Alarm related to the PTC temperature sensor installed in the motor. Note: - It may be disabled by setting P0351=0 or 2. - It is required to set the analog input / output to the PTC function.	<input checked="" type="checkbox"/> Excessive load at the motor shaft. <input checked="" type="checkbox"/> Excessive duty cycle (too many starts / stops per minute). <input checked="" type="checkbox"/> Surrounding air temperature too high. <input checked="" type="checkbox"/> Loose connection or short-circuit (resistance < 100 Ω) in the wiring connected to the motor thermistor. <input checked="" type="checkbox"/> Motor thermistor is not installed. <input checked="" type="checkbox"/> Blocked motor shaft.
A128: Timeout for Serial Communication	Indicates that the inverter stopped receiving valid messages within a certain time interval. Note: It may be disabled by setting P0314=0.0 s.	<input checked="" type="checkbox"/> Check the wiring and grounding installation. <input checked="" type="checkbox"/> Make sure the inverter has sent a new message within the time interval set at P0314.
A129: Anybus is Offline	Alarm that indicates interruption of the Anybus-CC communication.	<input checked="" type="checkbox"/> PLC entered into the idle state. <input checked="" type="checkbox"/> Programming error. Master and slave set with a different number of I/O words. <input checked="" type="checkbox"/> Communication with master has been lost (broken cable, unplugged connector, etc.).

Table 6.1 (cont.) - Faults, alarms and possible causes

Fault/Alarm	Description	Possible Causes
A130: Anybus Access Error	Alarm that indicates an access error to the Anybus-CC communication module.	<input checked="" type="checkbox"/> Defective, unrecognized, or improperly installed Anybus-CC module. <input checked="" type="checkbox"/> Conflict with a WEG option board.
A133: CAN Not Powered	Alarm indicating that the power supply was not connected to the CAN controller.	<input checked="" type="checkbox"/> Broken or loose cable. <input checked="" type="checkbox"/> Power supply is off.
A134: Bus Off	Inverter CAN interface has entered into the bus-off state.	<input checked="" type="checkbox"/> Incorrect communication baud-rate. <input checked="" type="checkbox"/> Two nodes configured with the same address in the network. <input checked="" type="checkbox"/> Wrong cable connection (inverted signals).
A135: CANopen Communication Error	Alarm that indicates a communication error.	<input checked="" type="checkbox"/> Communication problems. <input checked="" type="checkbox"/> Wrong master configuration/settings. <input checked="" type="checkbox"/> Incorrect configuration of the communication objects.
A136: Idle Master	Network master has entered into the idle state.	<input checked="" type="checkbox"/> PLC in IDLE mode. <input checked="" type="checkbox"/> Bit of the PLC command register set to zero (0).
A137: DNet Connection Timeout	I/O connection timeout - DeviceNet communication alarm.	<input checked="" type="checkbox"/> One or more allocated I/O connections have entered into the timeout state.
F150: Motor Overspeed	Overspeed fault. It is activated when the real speed exceeds the value of P0134+P0132 for more than 20 ms.	<input checked="" type="checkbox"/> Wrong settings of P0161 and/or P0162. <input checked="" type="checkbox"/> Problem with the hoist-type load.
F151: FLASH Memory Module Fault	FLASH Memory Module fault (MMF-01).	<input checked="" type="checkbox"/> Defective FLASH memory module. <input checked="" type="checkbox"/> Check the connection of the FLASH memory module.
A152: Internal Air High Temperature	Alarm indicating that the internal air temperature is too high. Note: It may be disabled by setting P0353=1 or 3.	<input checked="" type="checkbox"/> Surrounding air temperature too high (>45 °C (113 °F)) and excessive output current. <input checked="" type="checkbox"/> Defective internal fan.
F153: Internal Air Overtemperature	Internal air overtemperature fault.	
F156: Undertemperature	Undertemperature fault, measured at the IGBT temperature sensors.	<input checked="" type="checkbox"/> Surrounding air temperature ≤ -30 °C (-22 °F).
A177: Fan Replacement	Heatsink fan replacement alarm (P0045 > 50000 hours). Note: This function may be disabled by setting P0354=0.	<input checked="" type="checkbox"/> Maximum number of operating hours for the heatsink fan has been reached.
F179: Heatsink Fan Speed Fault	Heatsink fan speed feedback fault. Note: This function may be disabled by setting P0354=0.	<input checked="" type="checkbox"/> Dirt at the heatsink fan blades and ball bearings. <input checked="" type="checkbox"/> Heatsink fan defect.
A181: Invalid Clock Value	Invalid clock value alarm.	<input checked="" type="checkbox"/> It is necessary to set date and time at parameters P0194 to P0199. <input checked="" type="checkbox"/> Keypad battery is discharged, defective, or not installed.
F182: Pulse Feedback Fault	Indicates a fault on the output pulses feedback.	<input checked="" type="checkbox"/> Defect in the inverter internal circuitry.
F183: IGBT overload + Temperature	Overtemperature related to the IGBTs overload protection.	<input checked="" type="checkbox"/> Surrounding air temperature too high. <input checked="" type="checkbox"/> Operation with overload at frequencies below 10 Hz – consider the table 8.1 to 8.5 values according to the used switching frequency.
F185 Pre-charge Contactor Fault	Fault in the pre-charge contactor circuit.	<input checked="" type="checkbox"/> Open command fuse. Refer to section 3.2.3.1.2. <input checked="" type="checkbox"/> Phase loss at the input in L1/R or L2/S. <input checked="" type="checkbox"/> Defect in the pre-charge contactor and/or related circuit.

(1) Very long motor cables (longer than 100 meters) present a high parasite capacitance against the ground. The circulation of parasite currents through those capacitances may cause the ground fault circuit activation and thus disabling the inverter with F074, immediately after the inverter enabling. Possible solutions:

- Decrease the carrier frequency (P0297).
- Install an output reactor between the inverter and the motor.

6.3 SOLUTIONS FOR THE MOST FREQUENT PROBLEMS

Table 6.2 - Solutions for the most frequent problems

Problem	Point to be Verified	Corrective Action
Motor does not start	Incorrect wiring connection	1. Check all power and control connections. For instance, the digital inputs set to start/stop, general enable, or no external error shall be connected to the 24 Vdc or to DGND* terminals (refer to figure 3.18).
	Analog reference (if used)	1. Check if the external signal is properly connected. 2. Check the status of the control potentiometer (if used).
	Incorrect settings	1. Check if parameters are properly set for the application.
	Fault	1. Check if the inverter is not blocked due to a fault condition. 2. Check if terminals XC1:13 and XC1:11 are not shorted (short-circuit at the 24 Vdc power supply).
	Motor stall	1. Decrease motor overload. 2. Increase P0136, P0137 (V/f), or P0169/P0170 (vector control).
Motor speed fluctuates (oscillates)	Loose connection	1. Stop the inverter, turn off the power supply, and check and tighten all power connections. 2. Check all internal connections of the inverter.
	Defective reference potentiometer	1. Replace potentiometer.
	Oscillation of the external analog reference	1. Identify the cause of the oscillation. If it is caused by electrical noise, use shielded cables or separate from the power and control wiring.
	Incorrect settings (vector control)	1. Check parameters P0410, P0412, P0161, P0162, P0175, and P0176. 2. Refer to the Software Manual.
Motor speed too high or too low	Incorrect settings (reference limits)	1. Check if the values of P0133 (minimum speed) and P0134 (maximum speed) are properly set for the motor and application used.
	Control signal from the analog reference (if used)	1. Check the level of the reference control signal. 2. Check the settings (gain and offset) of parameters P0232 to P0249.
	Motor nameplate	1. Check if the motor has been properly sized for the application.
Motor does not reach the rated speed, or motor speed starts oscillating around the rated speed (Vector Control)	Settings	1. Decrease P0180. 2. Check P0410.
Off display	Keypad connections	1. Check the inverter keypad connection.
	Power supply voltage	1. Rated values shall be within the limits specified below: 220-230 V power supply: - Minimum: 187 V - Maximum: 253 V 380-480 V power supply: - Minimum: 323 V - Maximum: 528 V
	Mains supply fuses open	1. Replace fuses.
Motor does not operate in the field weakening region (Vector Control)	Settings	1. Decrease P0180.
Low motor speed and P0009 = P0169 or P0170 (motor operating with torque limitation), for P0202 = 4 - vector with encoder	Encoder signals are inverted or power connection is inverted	1. Check signals $\bar{A} - A, \bar{B} - B$, refer to the incremental encoder interface manual. If signals are properly installed, exchange two of the output phases. For instance U and V.

6.4 INFORMATION FOR CONTACTING TECHNICAL SUPPORT



NOTE!

For technical support and servicing, it is important to have the following information in hand:

- ☑ Inverter model;
- ☑ Serial number, manufacturing date, and hardware revision that are listed in the product nameplate (refer to item 2.4);
- ☑ Installed software version (check parameter P0023);
- ☑ Application data and inverter settings.

6.5 PREVENTIVE MAINTENANCE



DANGER!

- ☑ Always turn off the mains power supply before touching any electrical component associated to the inverter.
- ☑ High voltage may still be present even after disconnecting the power supply.
- ☑ To prevent electric shock, wait at least 10 minutes after turning off the input power for the complete discharge of the power capacitors.
- ☑ Always connect the equipment frame to the protective ground (PE). Use the adequate connection terminal in the inverter.



ATTENTION!

The electronic boards have electrostatic discharge sensitive components.

Do not touch the components or connectors directly. If needed, first touch the grounded metallic frame or wear a ground strap.

**Do not perform any withstand voltage test!
If needed, consult WEG.**

The inverters require low maintenance when properly installed and operated. Table 6.3 presents main procedures and time intervals for preventive maintenance. Table 6.4 provides recommended periodic inspections to be performed every 6 months after inverter start-up.

Table 6.3 - Preventive maintenance

Maintenance		Interval	Instructions
Fan replacement		After 50000 operating hours. ⁽¹⁾	Replacement procedure shown in figures 6.1 and 6.2.
Keypad battery replacement		Every 10 years.	Refer to chapter 4.
Electrolytic capacitors	If the inverter is stocked (not being used): "Reforming"	Every year from the manufacturing date printed in the inverter identification label (refer to item 2.4).	Apply power to the inverter (voltage between 220 and 230 Vac, single-phase or three-phase, 50 or 60 Hz) for at least one hour. Then, disconnect the power supply and wait at least 24 hours before using the inverter (reapply power).
	Inverter is being used: replace	Every 10 years.	Contact WEG technical support to obtain replacement procedures.

(1) The inverters are factory set for automatic fan control (P0352=2), which means that they will be turned on only when the heatsink temperature exceeds a reference value. Therefore, the operating hours of the fan will depend on the inverter usage conditions (motor current, output frequency, cooling air temperature, etc.). The inverter stores the number of operating hours of the fan in parameter P0045. When this parameter reaches 50000 operating hours, the keypad display will show alarm A177.

Table 6.4 - Recommended periodic inspections - Every 6 months

Component	Problem	Corrective Action
Terminals, connectors	Loose screws	Tighten
	Loose connectors	
Fans / Cooling system	Dirty fans	Cleaning
	Abnormal acoustic noise	Replace fan. Refer to figures 6.1 and 6.2.
	Blocked fan	
	Abnormal vibration	Check the fan connection.
	Dust in the cabinet air filter	
Printed circuit boards	Accumulation of dust, oil, humidity, etc.	Cleaning
	Odor	Replacement
Power module / Power connections	Accumulation of dust, oil, humidity, etc.	Cleaning
	Loose connection screws	Tighten
DC bus capacitors (DC link)	Discoloration / odor / electrolyte leakage	Replacement
	Expanded or broken safety valve	
	Frame expansion	
Power resistors	Discoloration	Replacement
	Odor	
Heatsink	Dust accumulation	Cleaning
	Dirty	

6.5.1 Cleaning Instructions

If needed to clean the inverter, follow the guidelines below:

Ventilation system:

- ☑ Disconnect the inverter power supply and wait at least 10 minutes.
- ☑ Remove the dust from the cooling air inlet by using a soft brush or a flannel.
- ☑ Remove the dust from the heatsink fins and from the fan blades by using compressed air.

Electronic boards:

- ☑ Disconnect the inverter power supply and wait at least 10 minutes.
- ☑ Remove the dust from the electronic board by using an anti-static brush or an ion air gun (Charges Burtes Ion Gun - reference A6030-6DESCO).
- ☑ If needed, remove the boards from the inverter.
- ☑ Always wear a ground strap.

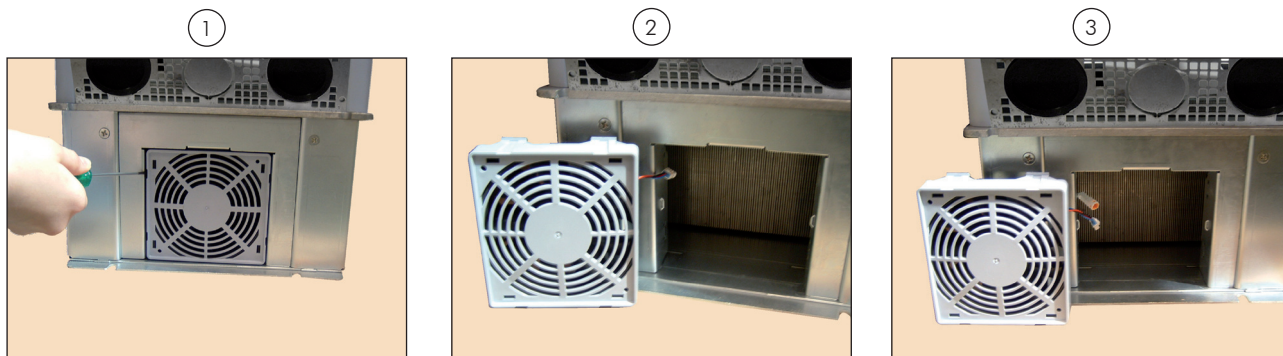

Fan cover locks release

Fan removal

Cable disconnection

(a) CFW11 0105 T 4 model

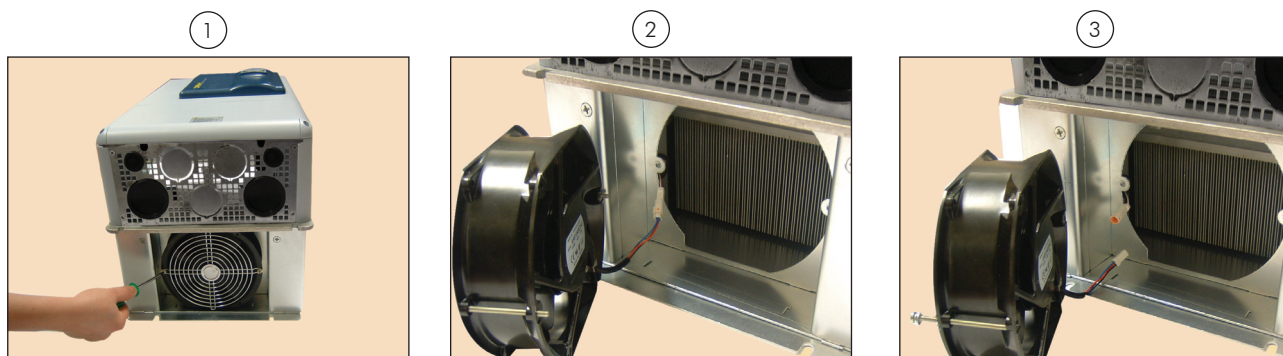

Fan grill screws removal

Fan removal

Cable disconnection

(b) CFW11 0142 T 2, CFW11 0180 T 2, CFW11 0211 T 2, CFW11 0142 T 4, CFW11 0180 T 4 and CFW11 0211 T 4 models

Figure 6.1 (a) and (b) - Heatsink fan removal

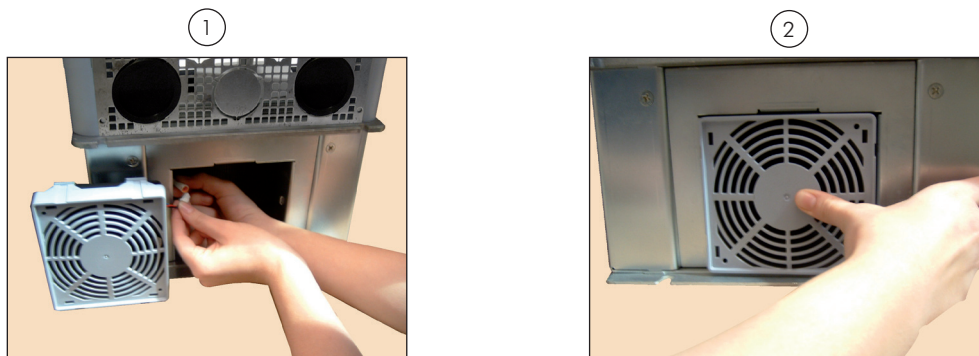

Cable connection

Fan fitting

(a) CFW11 0105 T 4 model

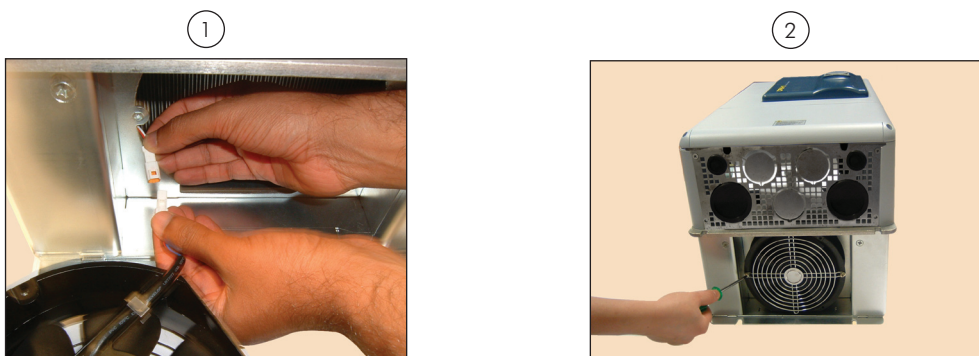

Cable connection

Fan and fan grill fastening

(b) CFW11 0142 T 2, CFW11 0180 T 2, CFW11 0211 T 2, CFW11 0142 T 4, CFW11 0180 T 4 and CFW11 0211 T 4 models

Figure 6.2 (a) and (b) - Heatsink fan installation

OPTION KITS AND ACCESSORIES

This chapter presents:

- ☑ The option kits that can be incorporated to the inverter from the factory:
 - Braking IGBT;
 - Safety Stop according to EN 954-1 category 3;
 - External 24 Vdc power supply for control and keypad.
- ☑ Instructions for the proper use of the option kits.
- ☑ The accessories that can be incorporated to the inverters.



Details for the installation, operation, and programming of the accessories are described in their own manuals and were not included in this chapter.

7.1 OPTION KITS

Some models cannot incorporate all available option kits. Refer to table 8.1 for a detailed description of the option kits that are available for each inverter model.

The inverter codification is described in chapter 2.

7.1.1 Braking IGBT

Inverters with the following codification: CFW11XXXXTXODB. Refer to item 3.2.3.2.

7.1.2 Nema1 Protection Degree

Inverters with the following codification: CFW11XXXXXXON1. Refer to items 3.1.5 and 8.4.

7.1.3 Safety Stop According to EN 954-1 Category 3 (Pending Certification)

Inverters with the following codification: CFW11XXXXXXOY.

The inverters with this option are equipped with an additional board (SRB2) that contains 2 safety relays and an interconnection cable with the power circuit.

Figure 7.1 shows the location of the SRB2 board and the location of the connector XC25 (used for the connection of the SRB2 board signals).

The relay coils are available through the connector XC25, as presented in table 7.1.



DANGER!

The activation of the Safety Stop, i.e., disconnection of the 24 Vdc power supply from the safety relay coil (XC25: 1(+) and 2(-); XC25:3(+) and 4(-)) does not guarantee the electrical safety of the motor terminals (they are not isolated from the power supply in this condition).

Operation:

1. The Safety Stop function is activated by disconnecting the 24 Vdc voltage from the safety relay coil (XC25:1(+) and 2(-); XC25:3(+) and 4(-)).
2. Upon activation of the Safety Stop, the PWM pulses at the inverter output will be blocked and the motor will coast to stop.
The inverter will not start the motor or generate a rotating magnetic field even in the event of an internal failure (pending certification).
The keypad will display a message informing that the Safety Stop is active.
3. Apply 24 Vdc voltage to the safety relay coil (XC25:1(+) and 2(-); XC25:3(+) and 4(-)) to get back to normal operation after activation of the Safety Stop.

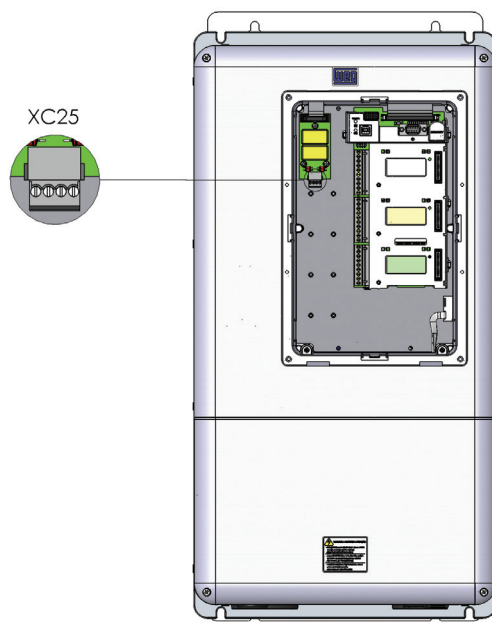

Figure 7.1 - Location of the SRB2 board in the frame size E CFW-11 inverters

Table 7.1 - XC25 connections

Connector XC25	Function	Specifications
1	R1 +	Rated coil voltage: 24 V, range from 20 to 30 Vdc Coil resistance: 960 Ω ±10 % @ 20 °C (68 °F)
2	R1 -	
3	R2 +	Rated coil voltage: 24 V, range from 20 to 30 Vdc Coil resistance: 960 Ω ±10 % @ 20 °C (68 °F)
4	R2 -	

7.1.4 24 Vdc External Control Power Supply

Inverters with the following codification: CFW11XXXXXXOW.

The use of this option kit is recommended with communication networks (Profibus, DeviceNet, etc.), since the control circuit and the network communication interface are kept active (with power supply and responding to the network communication commands) even in the event of main power supply interruption.

Inverters with this option have a built-in DC/DC converter with a 24 Vdc input that provides an adequate output for the control circuit. In such manner the power supply of the control circuit will be redundant, i.e., it can be provided by a 24 Vdc external power supply (connection as shown in figure 7.2) or by the standard internal switched-mode power supply of the inverter.

Observe that the inverters with the external 24 Vdc power supply option use terminals XC1:11 and 13 as the input for the external power supply and no longer as an output as in the standard inverter (figure 7.2).

In case of interruption of the external 24 Vdc power source, the digital inputs/outputs and analog outputs will have no power supply, even if the mains power is on. Therefore, it is recommended to keep the 24 Vdc power source always connected to terminals XC1:11 and 13.

The keypad displays warnings indicating the inverter status: if the 24 Vdc power source is connected, if the mains power source is connected, etc.

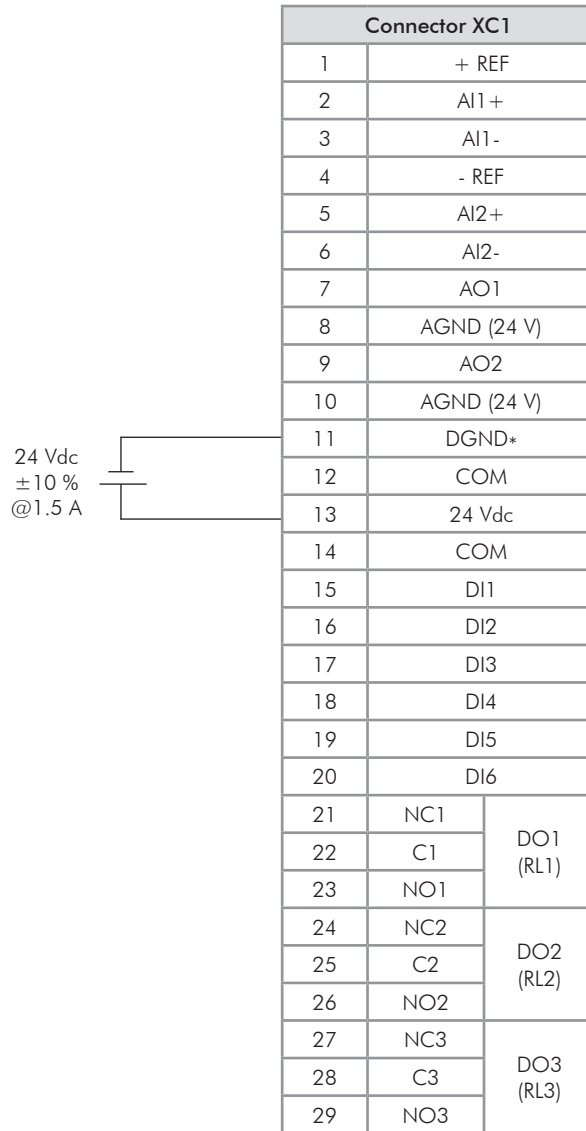

Figure 7.2 - Connection terminals and 24 Vdc external power supply rating



NOTE!

A class 2 power supply must be used to be in accordance to UL508C.

7.2 ACCESSORIES

The accessories are installed to the inverter easily and quickly using the "Plug and Play" concept. Once the accessory is connected to the slot, the control circuitry identifies the model and displays the installed accessory code in P0027 or P0028. The accessory shall be installed with the inverter power supply off.

Option Kits and Accessories

The code and model of each available accessory is presented in the table 7.2. The accessories can be ordered separately and will be shipped in an individual package containing the components and the manual with detailed instructions for the product installation, operation, and programming.



ATTENTION!

Only one module can be fitted at once in each slot (1, 2, 3, 4, or 5).

Table 7.2 - Accessory models

WEG Part Number	Name	Description	Slot	Identification Parameters	
				P0027	P0028
Control accessories for installation in the Slots 1, 2 and 3					
11008162	IOA-01	IOA module: 1 voltage/current analog input (14 bits); 2 digital inputs; 2 voltage/current analog outputs (14 bits); 2 open-collector digital outputs.	1	FD--	----
11008099	IOB-01	IOB module: 2 isolated analog inputs (voltage/current); 2 digital inputs; 2 isolated analog outputs (voltage/current) (the programming of the outputs is identical as in the standard CFW-11); 2 open-collector digital outputs.	1	FA--	----
11008100	ENC-01	5 to 12 Vdc incremental encoder module, 100 kHz, with an encoder signal repeater.	2	--C2	----
11008101	ENC-02	5 to 12 Vdc incremental encoder module, 100 kHz.	2	--C2	----
11008102	RS485-01	RS-485 serial communication module (Modbus).	3	----	CE--
11008103	RS232-01	RS-232C serial communication module (Modbus).	3	----	CC--
11008104	RS232-02	RS-232C serial communication module with DIP-switches for programming the microcontroller FLASH memory.	3	----	CC--
11008105	CAN/RS485-01	CAN and RS-485 interface module (CANopen / DeviceNet / Modbus).	3	----	CA--
11008106	CAN-01	CAN interface module (CANopen / DeviceNet).	3	----	CD--
11008911	PLC11-01	PLC module.	1, 2 and 3	----	--xx ⁽¹⁾⁽³⁾
Anybus-CC accessories for installation in the Slot 4					
11008107	PROFDP-05	ProfibusDP interface module.	4	----	--xx ⁽²⁾⁽³⁾
11008158	DEVICENET-05	DeviceNet interface module.	4	----	--xx ⁽²⁾⁽³⁾
10933688	ETHERNET/IP-05	Ethernet/IP interface module.	4	----	--xx ⁽²⁾⁽³⁾
11008160	RS232-05	RS-232 (passive) interface module (Modbus).	4	----	--xx ⁽²⁾⁽³⁾
11008161	RS485-05	RS-485 (passive) interface module (Modbus).	4	----	--xx ⁽²⁾⁽³⁾
Flash Memory Module for installation in the Slot 5 – Factory Settings Included					
11008912	MMF-01	FLASH memory module.	5	----	--xx ⁽³⁾
Stand-alone keypad, blank cover, and frame for remote mounted keypad					
11008913	HMI-01	Stand-alone keypad. ⁽⁴⁾	HMI	-	-
11010521	RHMIF-01	Remote keypad frame kit (IP56).	-	-	-
11010298	HMID-01	Blank cover for the keypad slot.	HMI	-	-
Miscellaneous					
10960842	KN1E-01	Nema1 kit for the frame size E models CFW11 0142 T 2, CFW11 0105 T 4 and CFW11 0142 T 4 (standard for N1 option). ⁽⁵⁾	-	-	-
10960850	KN1E-02	Nema1 kit for the frame size E models CFW11 0180 T 2, CFW11 0211 T 2, CFW11 0180 T 4 and CFW11 0211 T 4 (standard for N1 option). ⁽⁵⁾	-	-	-
10960844	PCSE-01	Kit for power cables shielding - frame E (included in the standard product).	-	-	-
10960847	CCS-01	Kit for control cables shielding (included in the standard product).	-	-	-
10960846	CONRA-01	Control rack (containing the CC11 control board).	-	-	-

(1) Refer to the PLC Module Manual.

(2) Refer to the Anybus-CC Communication Manual.

(3) Refer to the Software Manual.

(4) Use DB-9 pin, male-to-female, straight-through cable (serial mouse extension type) for connecting the keypad to the inverter or Null-Modem standard cable. Maximum cable length: 10 m (33 ft).

Examples:

- Mouse extension cable - 1.80 m (6 ft); Manufacturer: Clone.

- Belkin pro series DB9 serial extension cable 5 m (17 ft); Manufacturer: Belkin.

- Cables Unlimited PCM195006 cable, 6 ft DB9 m/f; Manufacturer: Cables Unlimited.

(5) Refer to the section 8.4 for more details.

TECHNICAL SPECIFICATIONS

This chapter describes the technical specifications (electric and mechanical) of the CFW-11 inverter series frame size E models.

8.1 POWER DATA

Power Supply:

- ☑ Voltage tolerance: -15 % to +10 %.
- ☑ Frequency: 50/60 Hz (48 Hz to 62 Hz).
- ☑ Phase imbalance: ≤ 3 % of the rated phase-to-phase input voltage.
- ☑ Overvoltage according to Category III (EN 61010/UL 508C).
- ☑ Transient voltage according to Category III.
- ☑ Maximum of 60 connections per hour (1 per minute).
- ☑ Typical efficiency: ≥ 97 %.
- ☑ Typical input power factor: 0.94 in nominal conditions.

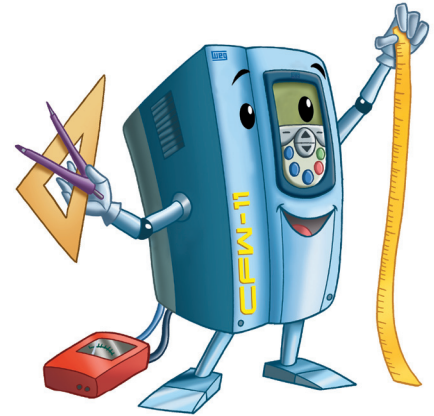

Table 8.1 - Technical specifications of the CFW-11 inverter series frame size E models

Model		Models with 220...230 V power supply			Models with 380...480 V power supply				
		CFW11 0142 T 2	CFW11 0180 T 2	CFW11 0211 T 2	CFW11 0105 T 4	CFW11 0142 T 4	CFW11 0180 T 4	CFW11 0211 T 4	
Frame		E							
Number of power phases		3 ϕ							
Use with Normal Duty (ND) cycle	Rated output current ⁽¹⁾ [Arms]	142	180	211	105	142	180	211	
	Overload current ⁽²⁾ [Arms]	1 min	156.2	198.0	232	115.5	156.2	198.0	232.1
		3 s	213	270	317	157.5	213.0	270	317
	Rated carrier frequency [kHz]	2.5	2.5	2.5	2.5	2.5	2.5	2.5	
	Maximum motor ⁽⁴⁾ [HP/kW]	50/37	60/45	75/55	75/55	100/75	150/110	175/132	
	Rated input current [Arms]	142.0	180.0	211.0	105.0	142.0	180.0	211.0	
	Dissipated power [W]	Surface mounting ⁽⁵⁾	1490	1820	2040	1270	1680	2050	2330
Flange mounting ⁽⁶⁾		210	360	360	200	210	360	360	
Use with Heavy Duty (HD) cycle	Rated output current ⁽¹⁾ [Arms]	115	142	180	88	115	142	180	
	Overload current ⁽²⁾ [Arms]	1 min	172.5	213	270	132.0	172.5	213.0	270
		3 s	230	284	360	176.0	230.0	284	360
	Rated carrier frequency [kHz]	5 ⁽³⁾	5 ⁽³⁾	2.5	2.5	2.5	2.5	2.5	
	Maximum motor ⁽⁴⁾ [HP/kW]	40/30	50/37	75/55	60/45	75/55	100/75	150/110	
	Rated input current [Arms]	115.0	142.0	180.0	88.0	115.0	142.0	180.0	
	Dissipated power [W]	Surface mounting ⁽⁵⁾	1280	1550	1690	1020	1290	1570	1940
Flange mounting ⁽⁶⁾		200	350	350	190	200	350	350	
Surrounding air temperature [°C (°F)]		-10...45 °C (14...113 °F)							
Dynamic braking		Optional (the standard product does not have dynamic braking)							
RFI filter		Built-in							
Weight [kg (lb)]		64.0 (141.1)	65.0 (143.3)	65.0 (143.3)	62.5 (137.8)	64.0 (141.1)	65.0 (143.3)	65.0 (143.3)	
Availability of option kits that can be incorporated into the product (refer to the intelligent code in chapter 2) ⁽⁷⁾	Cabinet enclosure	Yes, Nema1 (separated kit KN1E-01)	Yes, Nema1 (separated kit KN1E-02)		Yes, Nema1 (separated kit KN1E-01)		Yes, Nema1 (separated kit KN1E-02)		
	Dynamic braking	Yes							
	Safety stop	Yes							
	24 Vdc external control power supply	Yes							

Note:

(1) Steady-state rated current in the following conditions:

- Indicated carrier frequencies. For operation with higher switching frequencies (carrier frequency) it is necessary to derate output current according to the tables 8.2 to 8.5.
- Surrounding air temperature: -10 °C to 45 °C (14 °F to 113 °F). The inverter is capable of operating with an maximum surrounding air temperature of 55 °C (131 °F) if an output current derating of 2 % is applied for each °C (or 1.11 % each °F) above 45 °C (113 °F). This output current derating is valid for all the switching frequencies.
- Relative air humidity: 5 % to 90 % non-condensing.
- Altitude: 1000 m (3,300 ft). Above 1000 m (3,300 ft) up to 4000 m (13,200 ft) the output current shall be derated by 1 % for each 100 m (330 ft) above 1000 m (3,300 ft).
- Ambient with pollution degree 2 (according to EN50178 and UL508C).

(2) Table 8.1 presents only two points of the overload curve (activation time of 1 min and 3 s). The complete information about the IGBTs overload for Normal and Heavy Duty Cycles is presented below.

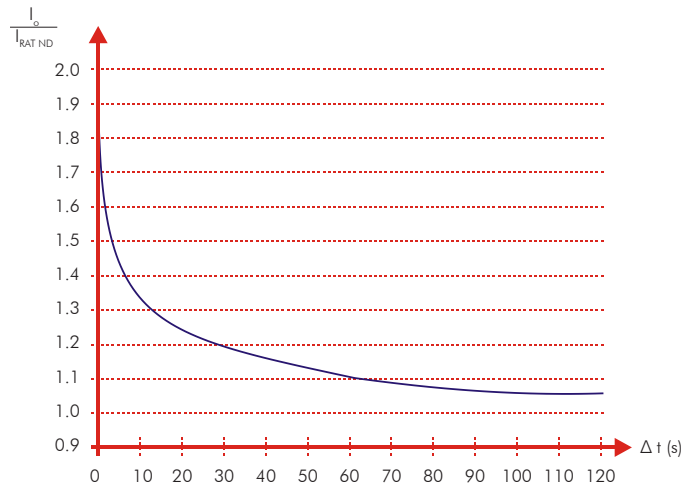

(a) IGBTs overload curve for the Normal Duty (ND) cycle

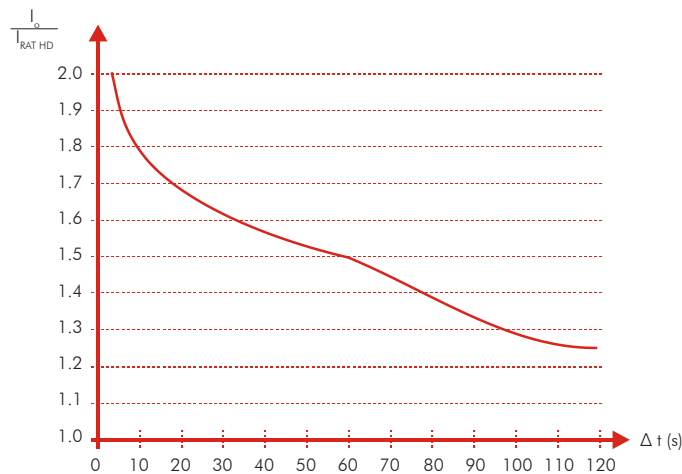

(b) IGBTs overload curve for the Heavy Duty (HD) cycle

Figure 8.1 (a) and (b) - Overload curves for the IGBTs

Depending on the inverter usage conditions (surrounding air temperature, output frequency, possibility or not of reducing the carrier frequency, etc.), the maximum time for operation of the inverter with overload may be reduced.

(3) The carrier frequency may be automatically reduced to 2.5 kHz depending on the operating conditions (surrounding air temperature, output current, etc.) - if P0350=0 or 1.

If it is necessary to operate always in 5 kHz, set P0350=2 or 3 and consider the nominal current values of the table 8.2 and 8.3. Note that in this case it is necessary to apply the derating to the nominal output current.

(4) The motor ratings are merely a guide for 230 V or 460 V, IV pole WEG motors. The adequate inverter sizing shall be based on the rated current of the motor used.

(5) The information provided about the inverter losses is valid for the rated operating condition, i.e., for rated output current and rated carrier frequency.

(6) The dissipated power provided for flange mounting corresponds to the total inverter losses disregarding the power module (IGBT and rectifier) losses.

Technical Specifications

(7) If the inverter is to be provided with this option, it should be specified in the intelligent identification code of the inverter.

Table 8.2 - Specifications of the CFW-11 series frame size E models for a switching frequency of 5 kHz and Ta=45 °C

Model	Frame	Number of power phases	Use with Normal Duty (ND) cycle						Use with Heavy Duty (HD) cycle								
			Rated output current [Arms] ⁽¹⁾	Overload current [Arms] ⁽²⁾		Maximum motor [HP/kW] ⁽⁴⁾	Rated input current [Arms]	Dissipated power [W]		Rated output current [Arms] ⁽¹⁾	Overload current [Arms] ⁽²⁾		Maximum motor [HP/kW] ⁽⁴⁾	Rated input current [Arms]	Dissipated power [W]		
				1 min	3 s			Surface mounting ⁽⁵⁾	Flange mounting ⁽⁶⁾		1 min	3 s			Surface mounting ⁽⁵⁾	Flange mounting ⁽⁶⁾	
Models with 220...230 V power supply	E	3φ	CFW11 0142 T 2	125.0	137.5	187.5	50/37	125.0	1420	200	102.0	153.0	204.0	40/30	102.0	1110	190
			CFW11 0180 T 2	159.0	174.9	239	60/45	159.0	1760	350	125.0	187.5	250	50/37	125.0	1360	340
			CFW11 0211 T 2	186.0	204.6	279	75/55	186.0	1990	350	159.0	239	318	60/45	159.0	1680	340
Models with 380...480 V power supply	E	3φ	CFW11 0105 T 4	82.0	90.2	123.0	60/45	82.0	1170	190	69.0	103.5	138.0	50/37	69.0	980	180
			CFW11 0142 T 4	111.0	122.1	166.5	75/55	111.0	1540	200	90.0	135.0	180.0	75/55	90.0	1230	190
			CFW11 0180 T 4	140.0	154.0	210.0	100/75	140.0	1910	350	111.0	166.5	222.0	75/55	111.0	1530	330
			CFW11 0211 T 4	164.0	180.4	246.0	125/90	164.0	2210	350	140.0	210.0	280.0	125/90	140.0	1900	340

Note:

- Verify notes for table 8.1.

Table 8.3 - Specifications of the CFW-11 series frame size E models for a switching frequency of 5 kHz and Ta=40 °C

Model	Frame	Number of power phases	Use with Normal Duty (ND) cycle						Use with Heavy Duty (HD) cycle								
			Rated output current [Arms] ⁽⁸⁾	Overload current [Arms] ⁽²⁾		Maximum motor [HP/kW] ⁽⁴⁾	Rated input current [Arms]	Dissipated power [W]		Rated output current [Arms] ⁽⁸⁾	Overload current [Arms] ⁽²⁾		Maximum motor [HP/kW] ⁽⁴⁾	Rated input current [Arms]	Dissipated power [W]		
				1 min	3 s			Surface mounting ⁽⁵⁾	Flange mounting ⁽⁶⁾		1 min	3 s			Surface mounting ⁽⁵⁾	Flange mounting ⁽⁶⁾	
Models with 220...230 V power supply	E	3φ	CFW11 0142 T 2	132.0	145.2	198.0	50/37	132.0	1520	210	108.0	162.0	216.0	40/30	108.0	1190	200
			CFW11 0180 T 2	168.0	184.8	252	60/45	168.0	1880	360	132.0	198.0	264	50/37	132.0	1440	340
			CFW11 0211 T 2	196.0	216	294	75/55	196.0	2120	360	168.0	252	336	60/45	168.0	1780	350
Models with 380...480 V power supply	E	3φ	CFW11 0105 T 4	87.0	95.7	130.5	75/55	87.0	1250	190	73.0	109.5	146.0	60/45	73.0	1030	180
			CFW11 0142 T 4	117.0	128.7	175.5	100/75	117.0	1630	200	95.0	142.5	190.0	75/55	95.0	1300	190
			CFW11 0180 T 4	148.0	162.8	222.0	125/90	148.0	2030	350	117.0	175.5	234.0	100/75	117.0	1600	340
			CFW11 0211 T 4	173.0	190.3	259.5	150/110	173.0	2340	350	148.0	222.0	296.0	125/90	148.0	2000	340

Note:

- Verify notes for table 8.1.

- (8)
- Surrounding air temperature: -10 to 40 °C (14 to 104 °F);
 - Relative air humidity: 5 % to 90 % non-condensing;
 - Altitude: 1000 m (3,300 ft). Above 1000 m (3,300 ft) up to 4000 m (13,200 ft) the output current shall be derated by 1 % for each 100 m (330 ft) above 1000 m (3,300 ft);
 - Ambient with pollution degree 2 (according to EN 50178 and UL 508C).

Table 8.4 - Specifications of the CFW-11 series frame size E models for a switching frequency of 10 kHz and Ta=45 °C

Model	Frame	Number of power phases	Use with Normal Duty (ND) cycle							Use with Heavy Duty (HD) cycle							
			Rated output current ⁽¹⁾ [Arms]	Overload current ⁽²⁾ [Arms]		Maximum motor ⁽⁴⁾ [HP/kW]	Rated input current [Arms]	Dissipated power [W]		Rated output current ⁽¹⁾ [Arms]	Overload current ⁽²⁾ [Arms]		Maximum motor ⁽⁴⁾ [HP/kW]	Rated input current [Arms]	Dissipated power [W]		
				1 min	3 s			Surface mounting ⁽⁵⁾	Flange mounting ⁽⁶⁾		1 min	3 s			Surface mounting ⁽⁵⁾	Flange mounting ⁽⁶⁾	
Models with 220...230 V power supply	E	3φ	CFW11 0142 T 2	100.0	110.0	150.0	40/30	100.0	1350	190	81.0	121.5	162.0	30/22	81.0	1090	190
			CFW11 0180 T 2	126.0	138.6	189	50/37	126.0	1690	340	100.0	150.0	200	40/30	100.0	1370	330
			CFW11 0211 T 2	148.0	162.8	222	60/45	148.0	1970	340	126.0	189	252	50/37	126.0	1700	330
Models with 380...480 V power supply	E	3φ	CFW11 0105 T 4	58.0	63.8	87.0	50/37	58.0	1170	180	49.0	73.5	98.0	40/30	49.0	1020	170
			CFW11 0142 T 4	79.0	86.9	118.5	60/45	79.0	1550	180	64.0	96.0	128.0	50/37	64.0	1290	180
			CFW11 0180 T 4	99.0	108.9	148.5	75/55	99.0	1950	330	79.0	118.5	158.0	60/45	79.0	1630	320
			CFW11 0211 T 4	117.0	128.7	175.5	100/75	117.0	2350	330	99.0	148.5	198.0	75/55	99.0	2070	320

Note:
- Verify notes for table 8.1.

Table 8.5 - Specifications of the CFW-11 series frame size E models for a switching frequency of 10 kHz and Ta=40 °C

Model	Frame	Number of power phases	Use with Normal Duty (ND) cycle							Use with Heavy Duty (HD) cycle							
			Rated output current ⁽⁸⁾ [Arms]	Overload current ⁽²⁾ [Arms]		Maximum motor ⁽⁴⁾ [HP/kW]	Rated input current [Arms]	Dissipated power [W]		Rated output current ⁽⁸⁾ [Arms]	Overload current ⁽²⁾ [Arms]		Maximum motor ⁽⁴⁾ [HP/kW]	Rated input current [Arms]	Dissipated power [W]		
				1 min	3 s			Surface mounting ⁽⁵⁾	Flange mounting ⁽⁶⁾		1 min	3 s			Surface mounting ⁽⁵⁾	Flange mounting ⁽⁶⁾	
Models with 220...230 V power supply	E	3φ	CFW11 0142 T 2	106.0	116.6	159.0	40/30	106.0	1440	200	86.0	129.0	172.0	30/22	86.0	1160	190
			CFW11 0180 T 2	133.0	146.3	200	50/37	133.0	1790	340	106.0	159.0	212	40/30	106.0	1440	330
			CFW11 0211 T 2	156.0	172	234	60/45	156.0	2070	340	133.0	200	266	50/37	133.0	1780	330
Models with 380...480 V power supply	E	3φ	CFW11 0105 T 4	62.0	68.2	93.0	50/37	62.0	1240	180	52.0	78.0	104.0	40/30	52.0	1070	180
			CFW11 0142 T 4	84.0	92.4	126.0	60/45	84.0	1640	190	68.0	102.0	136.0	50/37	68.0	1360	180
			CFW11 0180 T 4	105.0	115.5	157.5	75/55	105.0	2050	330	84.0	126.0	168.0	60/45	84.0	1710	320
			CFW11 0211 T 4	124.0	136.4	186.0	100/75	124.0	2460	330	105.0	157.5	210.0	75/55	105.0	2160	320

Note:
- Verify notes for table 8.1.

- (8)
- Surrounding air temperature: -10 to 40 °C (14 to 104 °F);
 - Relative air humidity: 5 % to 90 % non-condensing;
 - Altitude: 1000 m (3,300 ft). Above 1000 m (3,300 ft) up to 4000 m (13,200 ft) the output current shall be derated by 1 % for each 100 m (330 ft) above 1000 m (3,300 ft);
 - Ambient with pollution degree 2 (according to EN 50178 and UL 508C).

8.2 ELECTRICAL / GENERAL SPECIFICATIONS

CONTROL	METHOD	<ul style="list-style-type: none"> <input checked="" type="checkbox"/> Voltage source <input checked="" type="checkbox"/> Type of control: <ul style="list-style-type: none"> - V/f (Scalar); - VVW: Voltage Vector Control; - Vector control with encoder; - Sensorless vector control (without encoder). <input checked="" type="checkbox"/> PWM SVM (Space Vector Modulation); <input checked="" type="checkbox"/> Full digital (software) current, flux, and speed regulators. Execution rate: <ul style="list-style-type: none"> - current regulators: 0.2 ms (5 kHz) - flux regulator: 0.4 ms (2.5 kHz) - speed regulator / speed measurement: 1.2 ms
	OUTPUT FREQUENCY	<ul style="list-style-type: none"> <input checked="" type="checkbox"/> 0 to 3.4 x rated motor frequency (P0403). The rated frequency is programmable from 0 Hz to 300 Hz in the scalar mode and from 30 Hz to 120 Hz in the vector mode.
PERFORMANCE	SPEED CONTROL	<p><u>V/f (Scalar):</u></p> <ul style="list-style-type: none"> <input checked="" type="checkbox"/> Regulation (with slip compensation): 1 % of the rated speed. <input checked="" type="checkbox"/> Speed variation range: 1:20. <p><u>VVW:</u></p> <ul style="list-style-type: none"> <input checked="" type="checkbox"/> Regulation: 1 % of the rated speed. <input checked="" type="checkbox"/> Speed variation range: 1:30. <p><u>Sensorless:</u></p> <ul style="list-style-type: none"> <input checked="" type="checkbox"/> Regulation: 0.5 % of the rated speed. <input checked="" type="checkbox"/> Speed variation range: 1:100. <p><u>Vector with Encoder:</u></p> <ul style="list-style-type: none"> <input checked="" type="checkbox"/> Regulation: <ul style="list-style-type: none"> ±0.01 % of the rated speed with a 14-bits analog input (IOA); ±0.01 % of the rated speed with a digital reference (Keypad, Serial, Fieldbus, Electronic Potentiometer, Multispeed); ±0.05 % of the rated speed with a 12-bits analog input (CC11).
	TORQUE CONTROL	<ul style="list-style-type: none"> <input checked="" type="checkbox"/> Range: 10 to 180 %, regulation: ±5 % of the rated torque (with encoder); <input checked="" type="checkbox"/> Range: 20 to 180 %, regulation: ±10 % of the rated torque (sensorless above 3 Hz).
	INPUTS (CC11 board)	<p><u>ANALOG</u></p> <ul style="list-style-type: none"> <input checked="" type="checkbox"/> 2 isolated differential inputs; resolution of AI1: 12 bits, resolution of AI2: 11 bits + signal, (0 to 10) V, (0 to 20) mA or (4 to 20) mA, Impedance: 400 kΩ for (0 to 10) V, 500 Ω for (0 to 20) mA or (4 to 20) mA, programmable functions. <p><u>DIGITAL</u></p> <ul style="list-style-type: none"> <input checked="" type="checkbox"/> 6 isolated digital inputs, 24 Vdc, programmable functions.
OUTPUTS (CC11 board)	ANALOG	<ul style="list-style-type: none"> <input checked="" type="checkbox"/> 2 isolated analog outputs, (0 to 10) V, $R_L \geq 10 \text{ k}\Omega$ (maximum load), 0 to 20 mA / 4 to 20 mA ($R_L \leq 500 \Omega$) resolution: 11 bits, programmable functions.
	RELAY	<ul style="list-style-type: none"> <input checked="" type="checkbox"/> 3 relay outputs with NO/NC contacts, 240 Vac, 1 A, programmable functions.
SAFETY	PROTECTION	<ul style="list-style-type: none"> <input checked="" type="checkbox"/> Output overcurrent/short-circuit; <input checked="" type="checkbox"/> Under / Overvoltage; <input checked="" type="checkbox"/> Phase loss; <input checked="" type="checkbox"/> Overtemperature; <input checked="" type="checkbox"/> Braking resistor overload; <input checked="" type="checkbox"/> IGBTs overload; <input checked="" type="checkbox"/> Motor overload; <input checked="" type="checkbox"/> External fault / alarm; <input checked="" type="checkbox"/> CPU or memory fault; <input checked="" type="checkbox"/> Output phase-ground short-circuit.
INTEGRAL KEYPAD (HMI)	STANDARD KEYPAD	<ul style="list-style-type: none"> <input checked="" type="checkbox"/> 9 operator keys: Start/Stop, Up arrow, Down arrow, Direction of rotation, Jog, Local/Remote, Right soft key and Left soft key; <input checked="" type="checkbox"/> Graphical LCD display; <input checked="" type="checkbox"/> View/edition of parameters; <input checked="" type="checkbox"/> Indication accuracy: <ul style="list-style-type: none"> - current: 5 % of the rated current; - speed resolution: 1 rpm; <input checked="" type="checkbox"/> Possibility of remote mounting.

8.2 ELECTRICAL / GENERAL SPECIFICATIONS (cont.)

ENCLOSURE	IP20	☑ Inverters without Nema1 kit.
	NEMA1/IP20	☑ Inverters with Nema1 kit (KN1E-01 or KN1E-02).
	IP54	☑ Rear part of the inverter (external part for flange mounting).
PC CONNECTION FOR INVERTER PROGRAMMING	USB CONNECTOR	☑ USB standard Rev. 2.0 (basic speed); ☑ Type B (device) USB plug; ☑ Interconnection cable: standard host/device shielded USB cable.

8.2.1 Codes and Standards

SAFETY STANDARDS	☑ UL 508C - Power conversion equipment. ☑ UL 840 - Insulation coordination including clearances and creepage distances for electrical equipment. ☑ EN61800-5-1 - Safety requirements electrical, thermal and energy. ☑ EN 50178 - Electronic equipment for use in power installations. ☑ EN 60204-1 - Safety of machinery. Electrical equipment of machines. Part 1: General requirements. Note: The final assembler of the machine is responsible for installing an safety stop device and a supply disconnecting device. ☑ EN 60146 (IEC 146) - Semiconductor converters. ☑ EN 61800-2 - Adjustable speed electrical power drive systems - Part 2: General requirements - Rating specifications for low voltage adjustable frequency AC power drive systems.
ELECTROMAGNETIC COMPATIBILITY (EMC)	☑ EN 61800-3 - Adjustable speed electrical power drive systems - Part 3: EMC product standard including specific test methods. ☑ EN 55011 - Limits and methods of measurement of radio disturbance characteristics of industrial, scientific and medical (ISM) radio-frequency equipment. ☑ CISPR 11 - Industrial, scientific and medical (ISM) radio-frequency equipment - Electromagnetic disturbance characteristics - Limits and methods of measurement. ☑ EN 61000-4-2 - Electromagnetic compatibility (EMC) - Part 4: Testing and measurement techniques - Section 2: Electrostatic discharge immunity test. ☑ EN 61000-4-3 - Electromagnetic compatibility (EMC) - Part 4: Testing and measurement techniques - Section 3: Radiated, radio-frequency, electromagnetic field immunity test. ☑ EN 61000-4-4 - Electromagnetic compatibility (EMC) - Part 4: Testing and measurement techniques - Section 4: Electrical fast transient/burst immunity test. ☑ EN 61000-4-5 - Electromagnetic compatibility (EMC) - Part 4: Testing and measurement techniques - Section 5: Surge immunity test. ☑ EN 61000-4-6 - Electromagnetic compatibility (EMC)- Part 4: Testing and measurement techniques - Section 6: Immunity to conducted disturbances, induced by radio-frequency fields.
MECHANICAL STANDARDS	☑ EN 60529 - Degrees of protection provided by enclosures (IP code). ☑ UL 50 - Enclosures for electrical equipment.

8.4 NEMA1 KIT



- Weight of the KN1E-01 kit: 2.12 kg (4.67 lb)

(a) Frame E with the Nema1 kit KN1E-01 - CFW11 0142 T 2 O N1, CFW11 0105 T 4 O N1 and CFW11 0142 T 4 O N1 models

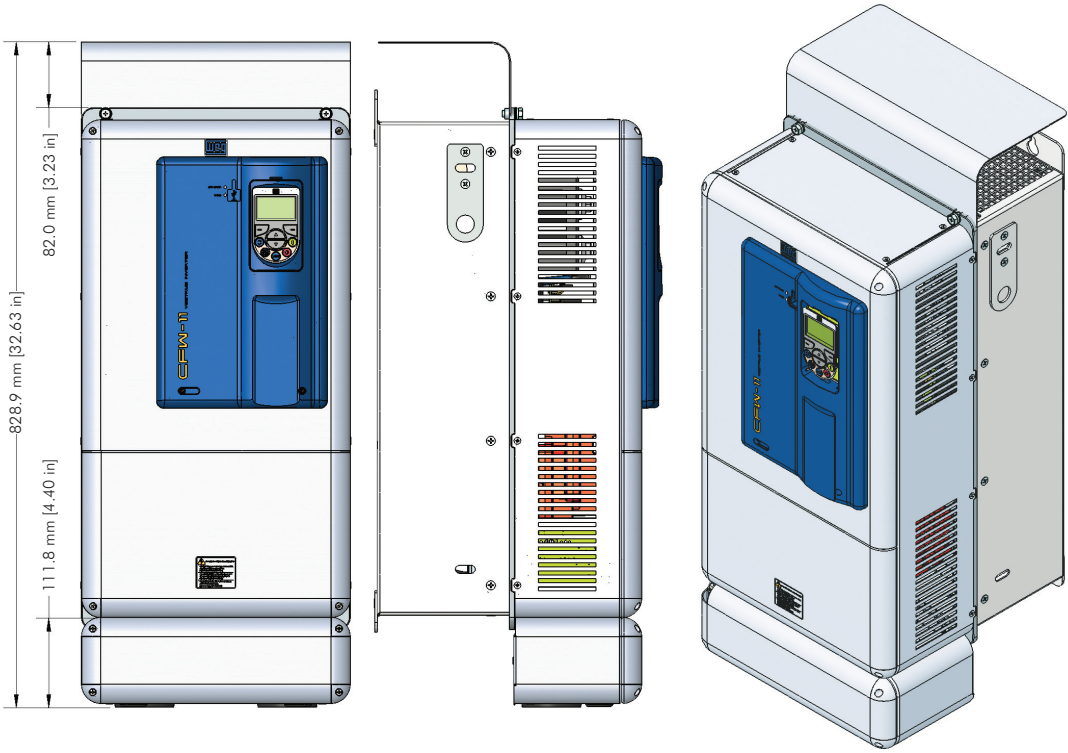

- Weight of the KN1E-02 kit: 4.3 kg (9.48 lb)

(b) Frame E with the Nema1 kit KN1E-02 - CFW11 0180 T 2 O N1, CFW11 0211 T 2 O N1, CFW11 0180 T 4 O N1 and CFW11 0211 T 4 O N1 models

Figure 8.3 (a) and (b) - Inverter with the Nema1 kit